

User Manual

Predator



THE SURFACE PREPARATION SPECIALISTS

CONTENTS

Introduction	3
Delivery.....	3
Grinder Specifications.....	4
Safety Warning	4
Controls and Features	5
Operation.....	6
Maintenance.....	7
Warranty	7
Service and Adjustment	8
Trouble Shooting.....	8
Faults Which Can Not Be Automatically Reset.....	9
Service Parts Diagrams.....	11
Predator Grinder Upper Belt Change	29
Predator Grinder Inner Belt Change	31

INNOVATECH

INTRODUCTION

Innovatech Products and Equipment Company specializes in the manufacturing and distribution of surface preparation equipment and supplies. From our early origins as a flooring removal company, and a foundation based upon the success of our Terminator line of flooring removal machines, Innovatech has transformed itself into an industry leader over a twelve year period.

Our continued growth can be attributed to our pledge to offer only premium products, our commitment to stand behind what we sell, and a staff well known throughout the industry for their knowledge and commitment to our valued customers. Based on customer need, Innovatech has proudly diversified our offerings to include a complete line of surface preparation products including Shot Blasters, Scarifiers, Floor Grinders, Dust Collectors, Diamond Abrasives, and other products.

NOTE: READ THIS MANUAL BEFORE YOU OPERATE OR SERVICE THE MACHINE.

DELIVERY

Upon arrival, the following items should be included:

- Splash Guard
- Upper Belt
- Spanner Wrench
- Manual
- Warranty Card

Splash Guard — #54-00025

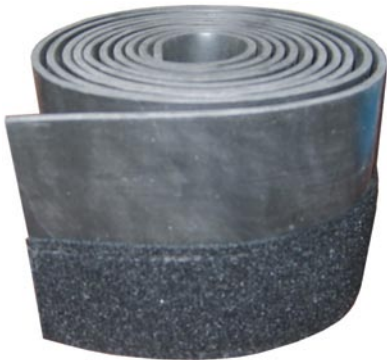

Upper Belt Carrier — #13-0164



Spanner Wrench — #53-0029



GRINDER SPECIFICATIONS

Dimensions Cutting Width: 24 Inches (610 mm)

Power: 7.5 Hp (5.5 kw) — 1 \emptyset 208 – 230 Volt, 0 – 28 Amp OR 3 \emptyset 208 – 230 Volt, 0 – 28 Amp
10 Hp (7.5 kw) — 3 \emptyset 390 – 460 Volt, 40 – 36 Amp

Dimensions: 49 x 25 46 Inches (125 x 64 x 117 cm)

Weight: 7.5 Hp — 568 Pounds (258 kg)

10 Hp — 652 Pounds (296 kg)

Speed RPM Heads: 180 – 900

Water Tank Capacity: 6 Gallons (22.75 L)

Grinding Discs: 4 x 8.5 Inches (4 x 212.5 mm)

Extension Cord: 50 Feet (15.24 m)

WARNING: DO NOT EXCEED 28 AMPS ON THE METER.

SAFETY WARNING

1. Only persons who have received training are permitted to operate or repair the grinder.
2. Use personal safety equipment such as steel toe shoes, safety glasses, and ear plugs.
3. Do not use grinder in area where there is a risk of explosion or fire.
4. Do not start the machine with heads off the ground.
5. Make sure the splash guard is on before starting machine.
6. Before you start grinding, check the floor for bolts, large holes and uneven joints. Hitting these things can damage machine, tools, and cause personal injury.
7. Make sure all power supply is connected with the right voltage.
8. Use only cold water in water tank. Do not use chemicals in water tank.
9. When filling water tank, to avoid electrical hazards and injury, do not spill water onto the machine motor and electrical box.
10. Switch off the machine power before changing grinding tools.
11. Disconnect power supply before working or repairing machine.
12. Be very careful with rolling machine on any sloping floors or ramps. The machine can roll very quickly. Two people may be needed to handle and control the machine.
13. Use caution with removing the grinding tools after finished grinding. Tools can be very hot. Use gloves to remove the plates.
14. When grinding glues, epoxy paints, or coatings, leaving the machine down on floor could cause the head to stick to the floor. Always tip back machine as soon as the head comes to a complete stop.
15. Always store machine in a dry place.
16. Only use Innovatech recommended tooling.
17. The operator must never leave the machine unattended during operation.
18. When grinding dry, use a suitable vacuum to extract the dust.
19. Innovatech is not responsible for any off gassing of hazardous gas that is generated by grinding materials. It is the responsibility of the operator. Grinding floors containing asbestos is especially dangerous and can cause health problems. Contact your state or country for the proper way to handle it.

CONTROLS AND FEATURES

- A. Lamp light is red with power on. Ready use.
- B. Emergency Stop: Push down to stop. Pull up to restart.
- C. Forward and Reverse.
- D. Manual Speed Pot: Controls the rotation of the grinding head. Turn the knob clockwise to increase the speed and counter-clockwise to decrease the speed.

NOTE: DO NOT USE THE EMERGENCY STOP BUTTON TO START THE MACHINE. THIS BUTTON IS DESIGNED FOR EMERGENCY USE ONLY.



OPERATION

Before starting:

1. Check the floor carefully and remove all bolts, nails, as well as any loose material that could get caught in the machine.
2. Fit the appropriate tools to the machine.
3. Fit splash guard to the right height.
4. Connect the power supply. Make sure you have all the phases. May have to check with volt meter.
5. If you are grinding dry, connect the appropriate vacuum and start vacuum before starting the grinder.

NOTE: IF THE WRONG POWER IS SUPPLIED TO THE GRINDER, IT WILL DAMAGE THE ELECTRICAL COMPONENTS IN THE INVERTERS.

Starting machine:

1. Turn main power switch on side of power box to ON.
2. Turn forward or reverse switch left of right.
3. Turn manual speed pot up to get the heads turning for desired speed. (If heads do not move, you may have to lean on handle to reduce pressure on tools.
4. Always grip handle firmly when starting machine. The machine will always move from side to side with first start.
5. When finished with grinding, turn off machine and let the heads come to a complete stop before tilting back the machine.

Changing of Tools:

1. Before working on the grinder, bring the motor to a total stop and disconnect power.
2. Tilt machine back on floor.
3. Use caution! Tools can be very hot from grinding. Use gloves.
4. Use special tool supplied to turn center of tool holder to remove tool plate.
5. Replace with new tool plate and turn to lock in place.
6. Lower machine back down and re-adjust splash guard is necessary. Working height of different tools varies depending on tools and wear.

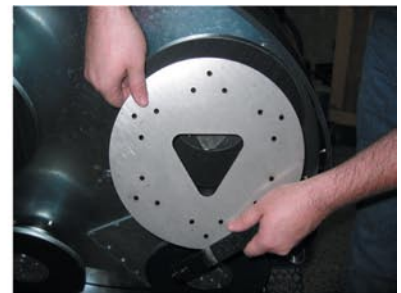
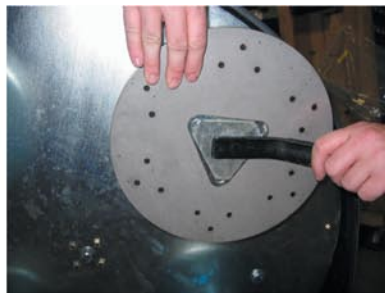
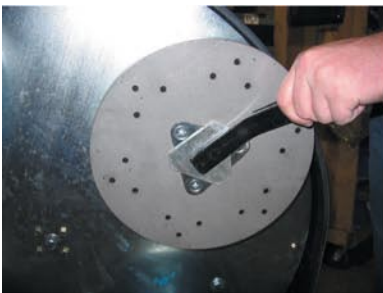

MAINTENANCE

Clean machine after every use. To clean machine, use a low pressure water hose or air pressure. Do not use a high PSI pressure washer. This could force water into areas of the machine unintentionally and damage parts. A regular inspection of machine for wear and damage should be done on a regular basis. If any parts have been damaged or have excessive wear, they should be replaced. If belts (Upper or Lower) are in need of being replaced, please see separate instructions.

WARRANTY

INNOVATECH warrants to original retail purchaser of the equipment:

A. **Limited Warranty.** The equipment, when first delivered, will conform to the specifications set forth in the Owner's Manual and will be without defect in material or workmanship.

For a period of one (1) year after delivery to the original retail purchaser, or 500 clock hours of operation, whichever occurs first; or in the case of replacement parts other than belts, for a period of ninety (90) days after the part is installed or within the warranty period described above, whichever is later, if the original retail purchaser notifies INNOVATECH (either directly or through one of INNOVATECH's authorized dealers) of a defect in material or workmanship or of a non-conformity to the specifications, then, upon confirmation of the defect of non-conformity and confirmation that the defect or non-conformity is covered within these Limited Warranty conditions, INNOVATECH will, at its election and at its expense, either (i) repair or correct the defect and/or non-conformity, or (ii) replace the part.

B. **Limitations.** This Limited Warranty does not apply to damage caused by (i) misuse of the equipment including, with limitation, use of the wrong power source, striking an imbedded object such as a bolt, electrical outlet box, expansion joint or steel reinforcing rod; or (ii) unauthorized alteration, modification, repair or tampering; or (iii) use of replacement parts not supplied by INNOVATECH; or (iv) normal wear, discoloration, surface corrosion, deterioration of finishes or paint surfaces, or (v) other appearance deterioration caused primarily by use. INNOVATECH shall not be responsible and this Limited Warranty shall not apply to damage caused by improper maintenance or failure to inspect and maintain the equipment as recommended in the Owner's Manual.

C. **Belts.** The equipment, when shipped from the factory is equipped with a spare Upper Drive Belt and the Upper Drive Belt is, therefore, not a covered item under the terms of this Limited Warranty. The Lower Drive Belt is covered as set out at paragraph A., above, but for the period of six (6) months after delivery of 250 clock hours of operation, whichever occurs first.

D. **Transportation.** Purchaser will pay the cost of transporting defective or non-conforming parts to INNOVATECH and the cost of returning repaired or replacement parts to purchaser. Each party will safely package the parts it sends to the other in accordance with good commercial practice. If purchaser requests and INNOVATECH agrees, INNOVATECH may perform covered warranty work where the equipment is located. If INNOVATECH performs the work at the location, purchaser will pay the cost of business class transportation and good quality meals and lodging for INNOVATECH's technicians.

E. **Abuse.** INNOVATECH IS NOT RESPONSIBLE FOR DAMAGE, DEFECT, BREAKAGE OR MALFUNCTION OF THE EQUIPMENT THAT IS CAUSED BY ABUSE OR BY OPERATION OF THE EQUIPMENT IN A MANNER WHICH IS NOT RECOMMENDED OR APPROVED BY INNOVATECH.

F. **Exclusive Warranty.** EXCEPT AS IS EXPRESSLY SET OUT IN THIS LIMITED WARRANTY: (i) INNOVATECH MAKES NO PROMISE OR WARRANTY, EXPRESSED OR IMPLIED, WITH RESPECT TO THE EQUIPMENT; (ii) INNOVATECH MAKES NO PROMISE OR WARRANTY THAT THE EQUIPMENT IS FIT FOR ANY PARTICULAR PURPOSE; (iii) INNOVATECH WILL HAVE NO OBLIGATION OR LIABILITY TO THE PURCHASER OR TO ANY THIRD PARTY WITH FOR ANY DAMAGE CAUSED BY THE EQUIPMENT OR AS A RESULT OR CONSEQUENCE OF ANY CLAIMED DEFECT IN THE EQUIPMENT, ANY FAILURE TO WARN OR NOTIFY, OR ANY CLAIMED NON-CONFORMITY TO THE SPECIFICATIONS; AND (iv) PURCHASER WILL HAVE NO OTHER REMEDIES IN RESPECT OF SUCH DEFECT, NON-CONFORMITY, DAMAGE OR CONDITION EXCEPT THOSE SET OUT IN THIS LIMITED WARRANTY.

WITHOUT LIMITING THE FOREGOING, AND REGARDLESS OF THE CIRCUMSTANCES AND EVEN IF A REMEDY FAILS, INNOVATECH WILL HAVE NO LIABILITY TO THE PURCHASER OR TO ANY THIRD PARTY FOR (i) LOSS OF REVENUE OR PROFITS, OR (ii) FOR INCIDENTAL, CONSEQUENTIAL OR PUNITIVE DAMAGES.

SERVICE AND ADJUSTMENT

A warranty will not be valid unless a written claim authorization comes with returned parts. Innovatech will not provide for any shipping costs for items returned for repair. To obtain warranty repairs, buyer must prepay shipment and return all warranty parts to Innovatech. Damage occurring during shipment is deemed the responsibility of the carrier and claims should be made directly with such carrier.

It will be the customer's responsibility to pay for any non-warranty replacement parts plus the current hourly labor rates for any work done on any machine or part. Service is available upon request; call Innovatech for current labor rates.

TROUBLESHOOTING

1. Check to see if main power supply is on.
2. Check to see if emergency stop is pushed down; if it is, pull up.
3. Check to see if manual speed pot is turned up past 1.
4. Check all cords ends for loose connection.
5. Check fuse in distribution box with test meter.
6. Check to see if all phase are with right voltage (check with volt meter).
7. Check the converter connector cable to motor.
8. Check for error message on display of the converter.

FAULTS WHICH CANNOT BE AUTOMATICALLY RESET

Faults which cannot be automatically reset are listed in the table below. To clear these faults:

1. Remove power from the drive controller.
2. Wait for the display to go off completely.
3. Determine the cause of the fault and correct it.
4. Re-apply power.

Fault	Probable Cause	Remedy
b L F Brake sequence	<ul style="list-style-type: none"> • Brake release current not reached 	<ul style="list-style-type: none"> • Check the drive controller and motor connections. • Check the motor windings.
C r F Precharge circuit fault	<ul style="list-style-type: none"> • Precharge circuit damaged 	<ul style="list-style-type: none"> • Reset the drive controller. • Replace the drive controller.
I n F Internal fault	<ul style="list-style-type: none"> • Internal fault • Internal connection fault 	<ul style="list-style-type: none"> • Remove sources of electromagnetic interference. • Replace the drive controller.
O C F Over current	<ul style="list-style-type: none"> • Incorrect parameter settings in the Set- and drC- menus • Acceleration too rapid • Drive controller and/or motor undersized for load • Mechanical blockage 	<ul style="list-style-type: none"> • Clear the mechanical blockage.
S C F Motor short circuit	<ul style="list-style-type: none"> • Short circuit or grounding at the drive controller output • Significant ground leakage current at the drive controller output if several motors are connected in parallel 	<ul style="list-style-type: none"> • Check the cable connecting the drive controller to the motor and check the motor insulation. • Reduce the switching frequency.
S O F Over speed	<ul style="list-style-type: none"> • Instability • Overhauling load 	<ul style="list-style-type: none"> • Check the size of the motor, drive controller, and load.
F n F Auto-Tuning fault	<ul style="list-style-type: none"> • Motor or motor power not suitable for the drive controller • Motor not connected to the drive controller 	<ul style="list-style-type: none"> • Check the presence of the motor during auto-tuning. • If a downstream contractor is being used, close it during auto-tuning.
E P F External fault	<ul style="list-style-type: none"> • User defined 	<ul style="list-style-type: none"> • User defined
L F F	<ul style="list-style-type: none"> • Loss of the 4-20 mA reference on input A13 	<ul style="list-style-type: none"> • Check the connection on input A13. • Loss of 4-20 mA follower

FAULTS WHICH CANNOT BE AUTOMATICALLY RESET

Fault	Probable Cause	Remedy
O b F Over voltage during deceleration	<ul style="list-style-type: none"> • Braking too rapidly • Overhauling load 	<ul style="list-style-type: none"> • Increase the deceleration time.
O H F Drive overload	<ul style="list-style-type: none"> • Drive controller or ambient temperature is too high. • Continuous motor current load is too high. 	<ul style="list-style-type: none"> • Check the motor load, the drive controller ventilation, and the environment. Wait for the drive controller to cool before restarting.
O L F Motor overload	<ul style="list-style-type: none"> • Thermal trip due to prolonged motor overload • Motor power rating too low for the application 	<ul style="list-style-type: none"> • Allow the motor to cool before restarting.
O P F Motor phase failure	<ul style="list-style-type: none"> • Loss of phase at drive controller output • Downstream contractor open • Motor not connected • Instability in the motor current • Drive controller oversized for motor 	<ul style="list-style-type: none"> • Check the connections from the drive controller to the motor. • Test the drive controller on a low power motor or without a motor: set OPL to nO.
O S F Over voltage during steady state operation or during acceleration	<ul style="list-style-type: none"> • Line voltage too high • Line supply transients 	<ul style="list-style-type: none"> • Check the line voltage. Compare with the drive controller nameplate rating. • Reset the drive controller.
P H F Input phase failure	<ul style="list-style-type: none"> • Input phase loss, blown fuse • Three-phase drive controller used on a single phase line supply • Input phase imbalance • Transient phase fault <p><i>NOTE: This protection only operates with the drive controller running under load.</i></p>	<ul style="list-style-type: none"> • Check the connections and the fuses. • Verify that the input power is correct. • Supply three-phase power if needed.
C F F Configuration fault	<ul style="list-style-type: none"> • The parameter configurations are not suited to the application. 	<ul style="list-style-type: none"> • Restore the factory settings or load the backup configuration, if it is valid.
U S F Under voltage	<ul style="list-style-type: none"> • Line supply too low • Transient voltage dip • Damaged precharge resistor 	<ul style="list-style-type: none"> • Check the line voltage. • Replace the drive controller.

SERVICE PARTS DIAGRAMS

Grinder Final Assembly

10 Horse Power, 3 Phase Motor — Part # 96-0083

7.5 Horse Power, 1 Phase Motor — Part # 96-0084

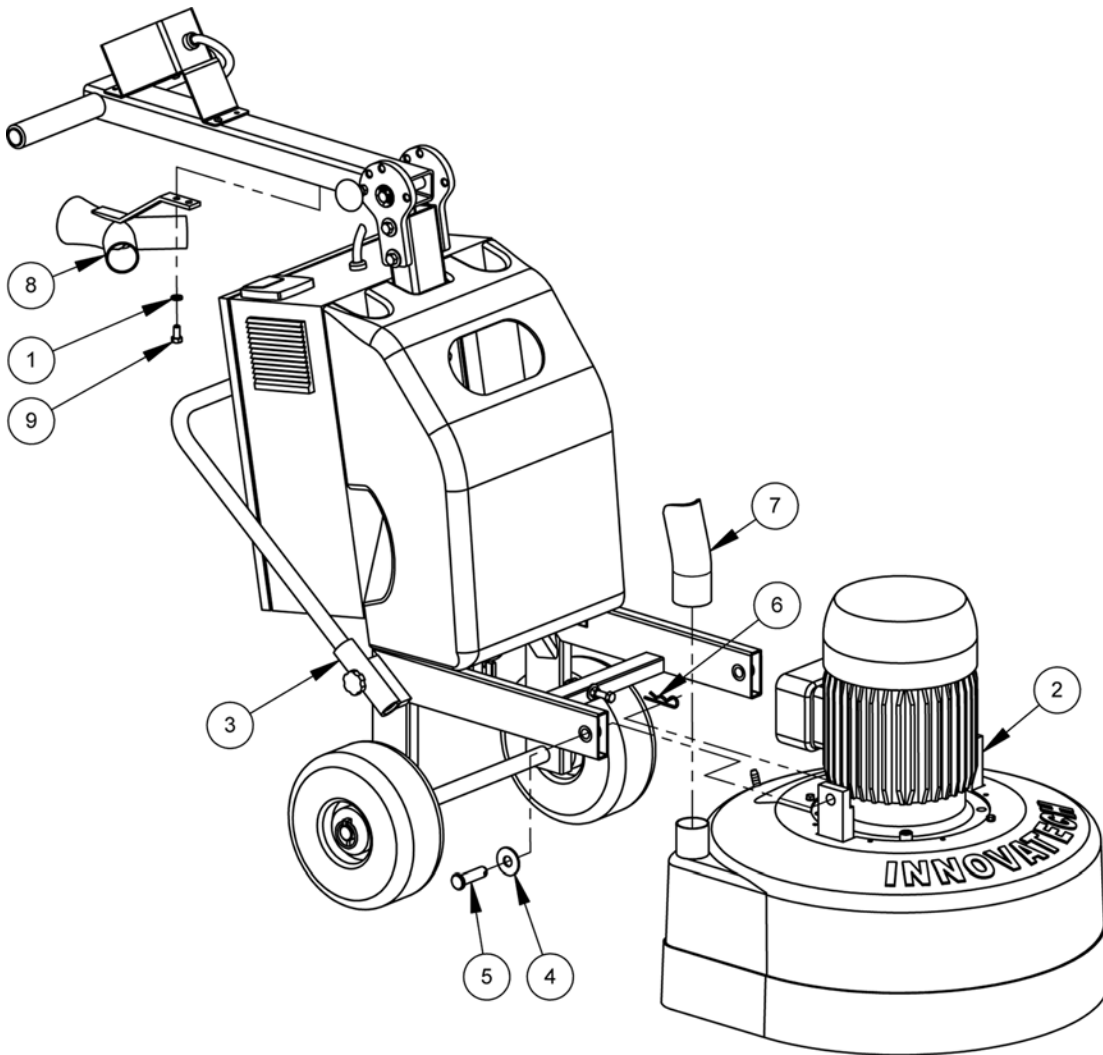

ITEM	DESCRIPTION	PART #	QTY
1	Washer (split lock), 3/8	11-0129	2
2	Grinder head assy	see note 2	1
3	Frame assy (complete build-up)	see note 2	1
4	Washer, 5/8	11-0148	2
5	Pin (clevis), 5/8 dia. x 2-1/2 long	11-0082	2
6	Pin (hairpin cotter)	11-0052	2
7	Vacuum hose, 2" ID	825-0003 see note 3	2
8	Coupler (Y-connector for vacuum hose)	804-0434	1
9	Screw (hex head), 3/8 - 16 x 3/4	11-0130	2

REV --

NOTES:

- FOR ILLUSTRATION SIMPLICITY, NOT ALL PARTS ARE SHOWN OR LABELED.
- GRINDER WITH 10 HP 3-PHASE MOTOR: GRINDER HEAD ASSY PART # 96-0077, FRAME ASSY PART # 96-0081.
GRINDER WITH 7.5 HP 1-PHASE MOTOR: GRINDER HEAD ASSY PART # 96-0078, FRAME ASSY PART # 96-0082.
- VACUUM HOSE IS PRE-CUT INTO 51" LONG SECTION.

Frame Assembly (Complete Build-Up)

10 Horse Power, 3 Phase Motor — Part # 96-0081

7.5 Horse Power, 1 Phase Motor — Part # 96-0082

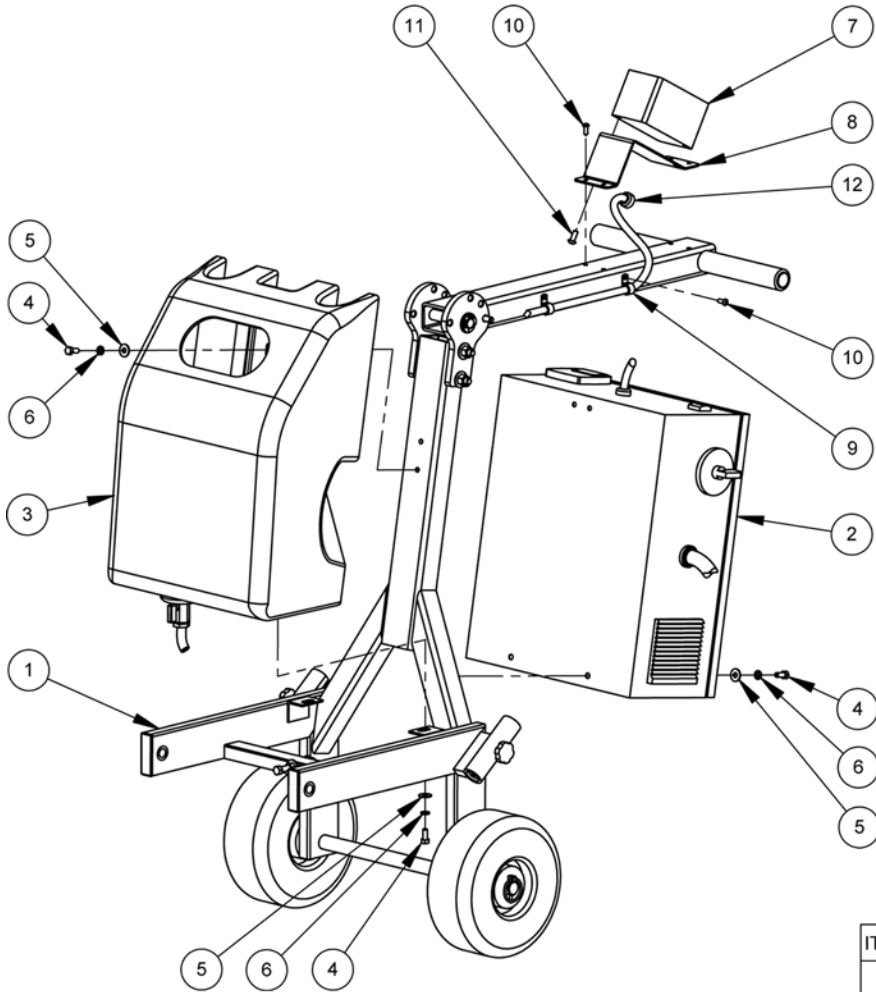

ITEM	DESCRIPTION	PART #	QTY
1	Frame structure	96-0070	1
2	Inverter box	see note 2	1
3	Water tank assy	96-0071	1
4	Screw (hex head), 5/16 - 18 x 3/4	11-0118	8
5	Washer, 5/16	11-0139	8
6	Washer (split lock), 5/16	11-0127	8
7	Power control box	see note 2	1
8	Bracket	52-0031	1
9	P-clamp (1/2" cable size)	13-0151	2
10	Screw (socket button head), 1/4 - 20 x 5/8	11-0152	6
11	Screw (socket button head), 5/16 - 18 x 3/4	11-0217	2
12	Cable (between control box and inverter box)	see note 2	1

REV --

NOTES:

- FOR ILLUSTRATION SIMPLICITY, NOT ALL DUPLICATE ITEMS ARE SHOWN OR LABELED.
- INVERTER BOX, POWER CONTROL BOX, AND CONNECTING CABLE ARE PRE-WIRED TOGETHER AS ONE UNIT.
INVERTER UNIT OPTIONS: USE PART # 96-0072 FOR 10 HP 3-PHASE MOTOR, PART # 96-0073 FOR 7.5 HP 1-PHASE MOTOR.
- INVERTER PROTECTION BAR IS PART OF FRAME STRUCTURE, AND IS NOT SHOWN HERE DUE TO SPACE CONSTRAINTS.

Frame Structure — Part # 96-0070

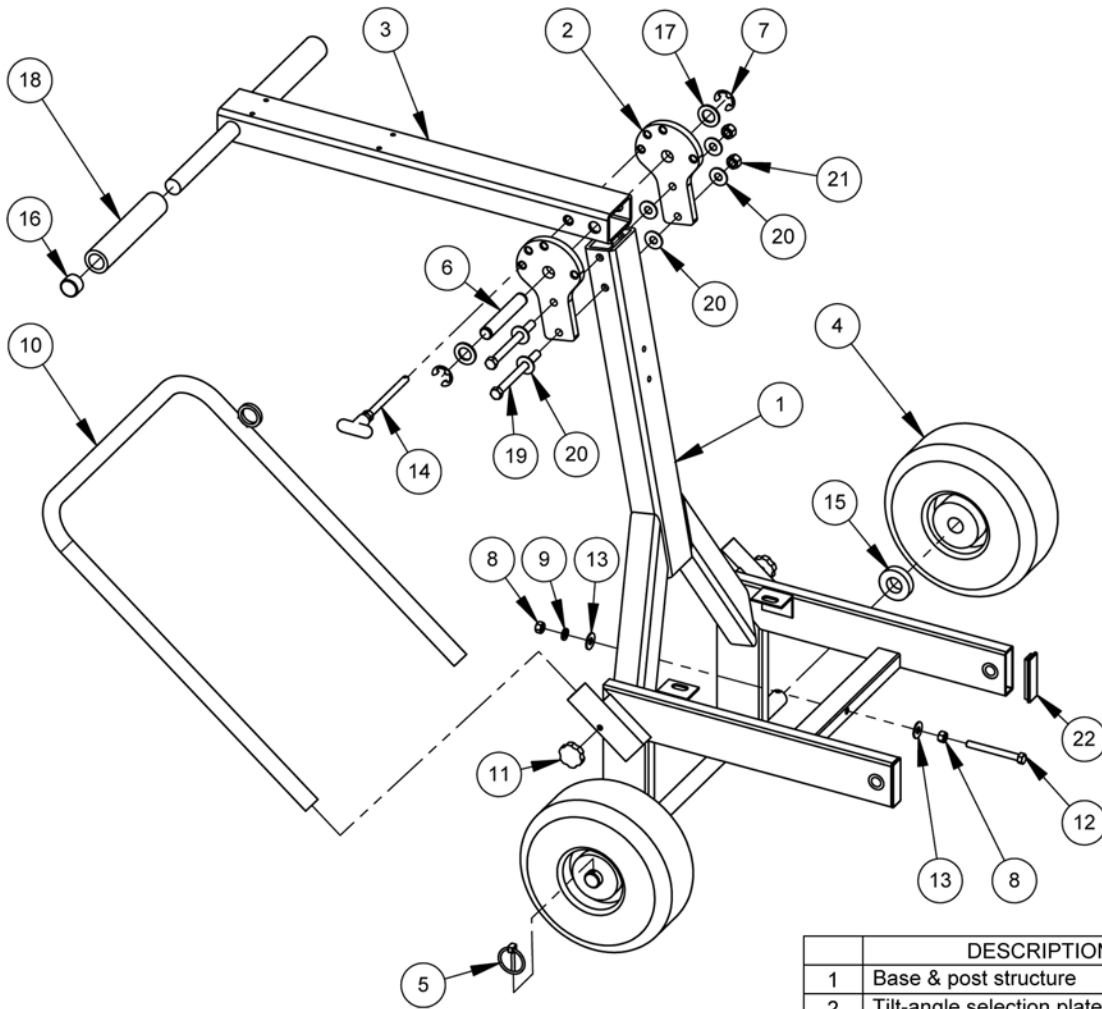

	DESCRIPTION	PART #	QTY
1	Base & post structure	53-0030	1
2	Tilt-angle selection plate	51-0233	2
3	Handle post structure	53-0034	1
4	Wheel	54-0000	2
5	Linch pin (fits 1-1/4 dia. shaft)	13-0162	2
6	Pin (handle hinge)	51-0187	1
7	Retaining ring (E-style)- fits 7/8 dia. shaft	13-0137	2
8	Nut, 3/8 - 16	11-0124	3
9	Washer (split lock), 3/8	11-0129	1
10	Inverter protection bar	53-0036	1
11	Thumb screw (5/16 - 18 x 1/2)	11-0215	2
12	Screw (hex head), 3/8 - 16 x 3-1/2	11-0218	1
13	Washer, 3/8	11-0126	2
14	Pin (handle post tilt lock)	96-0067	1
15	Spacer ring, 1 ID x 2 OD x 1/2 thk	51-0265	2
16	End cap, 1" dia.	81-0102	2
17	Washer, 3/4	11-0137	2
18	Handle grip (liner)	81-0101	2
19	Screw (hex head), 7/16 - 14 x 5	11-0219	2
20	Washer, 7/16	11-0036	6
21	Nut (nylon-insert locknut), 7/16 - 14	11-0027	2
22	End cap, 1" x 3" rectangle	13-0170	2

REV --

NOTES:
 FOR ILLUSTRATION SIMPLICITY, NOT ALL DUPLICATE
 ITEMS ARE SHOWN OR LABELED.

Water Tank — Part # 96-0071

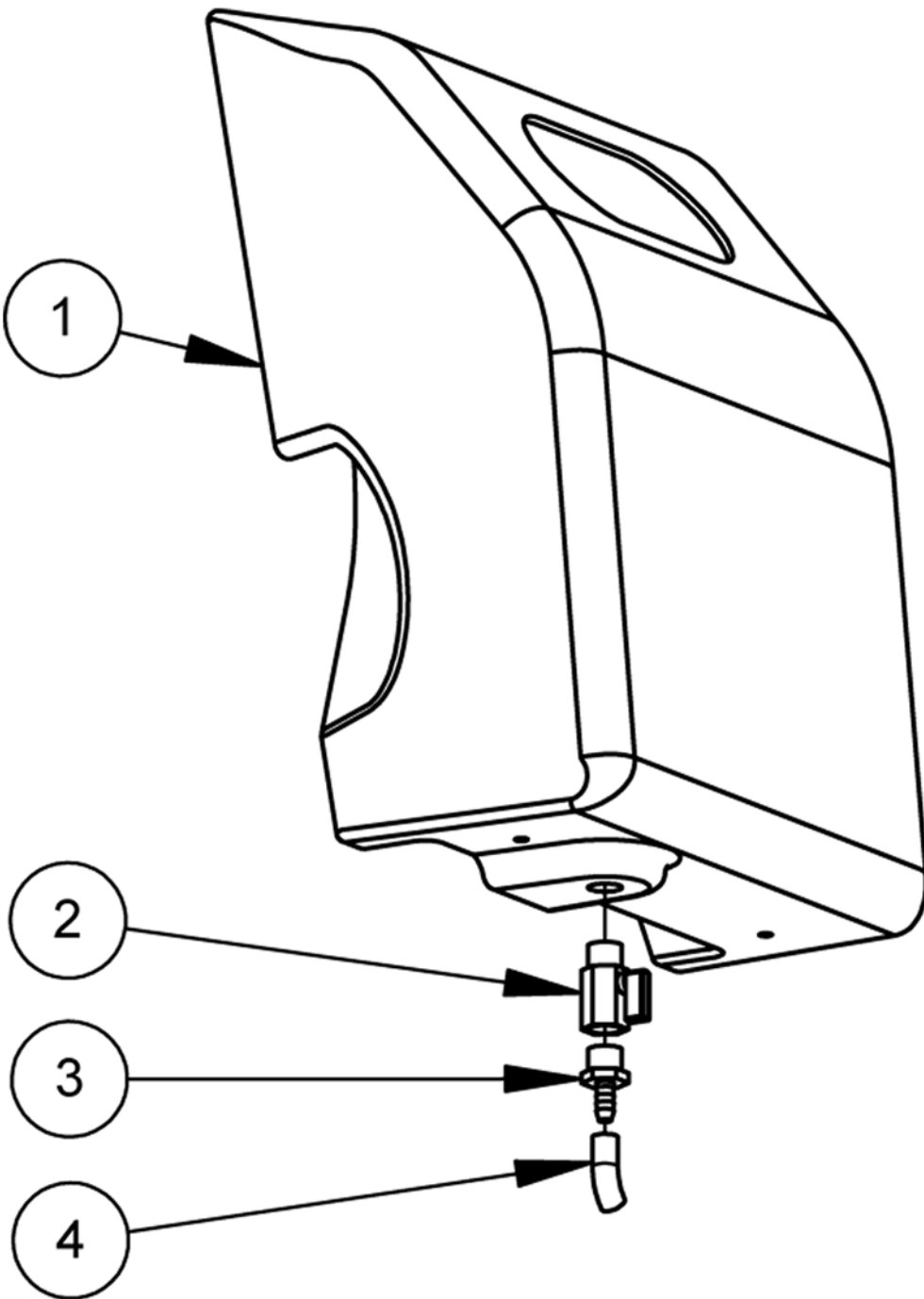

ITEM	DESCRIPTION	PART #	QTY
1	Water tank	54-0017	1
2	Drain valve	32-0010	1
3	Coupler (w/ 1/2" pipe threads and 3/8" barbed end)	32-0011	1
4	Tubing (3/8 ID x 5/8 OD x 10" long)	32-0013	1

REV --

Grinder Head

10 Horse Power, 3 Phase Motor — Part # 96-0077

7.5 Horse Power, 1 Phase Motor — Part # 96-0078

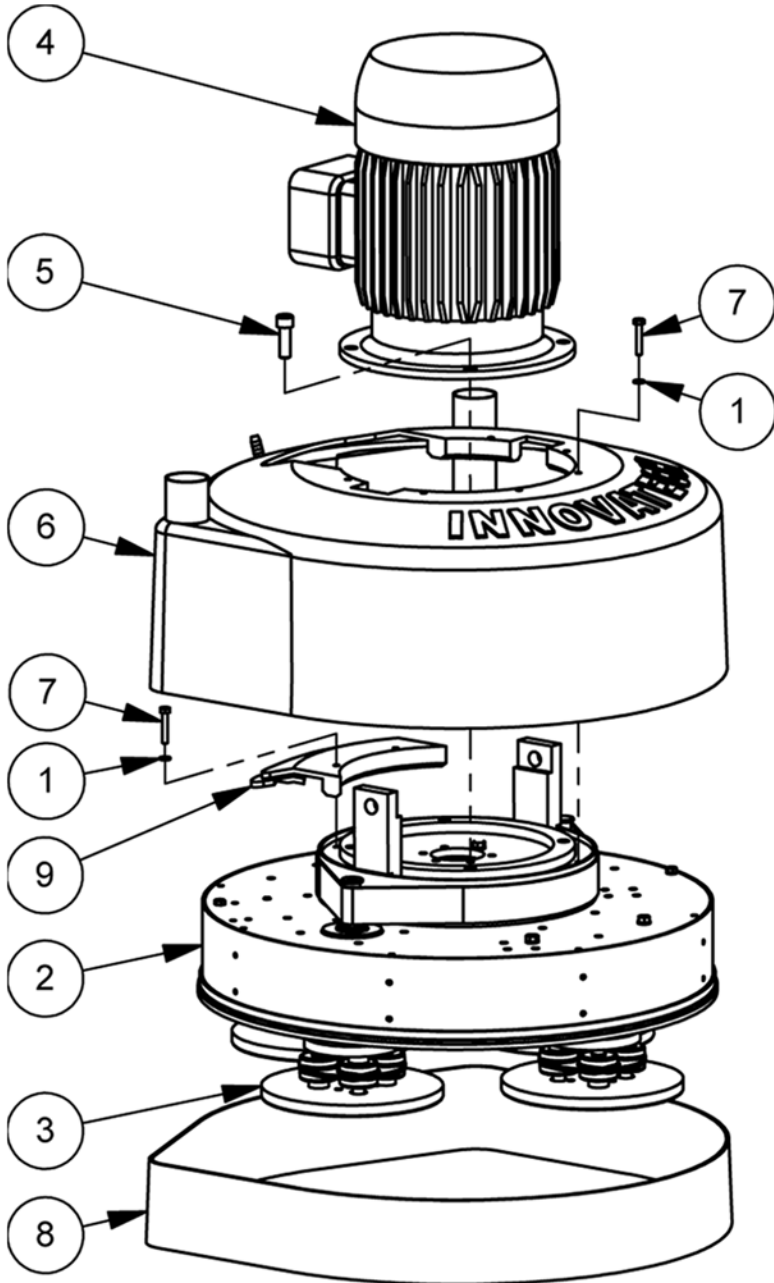

ITEM	DESCRIPTION	PART #	QTY
1	Washer (split lock), 1/4	11-0069	8
2	Drum [drive] unit	see note 3	1
3	Cutter head floating head assy	96-0065	4
4	Motor	see note 2	1
5	Screw (socket head), 1/2 - 13 x 1-1/2	11-0119	4
6	Shroud assy	96-0075	1
7	Screw (hex head), 1/4 - 20 x 1-1/2	11-0159	8
8	Splash guard	54-0002S	1
9	Shroud- cut-out panel	54-0019	1

REV --

NOTE:

1. FOR ILLUSTRATION SIMPLICITY, NOT ALL PARTS ARE SHOWN OR LABELED.
2. MOTOR OPTIONS:
 - 10 HP, 3-PHASE: PART # 23-0058.
 - 7.5 HP, 1-PHASE: PART # 23-0062.
3. DRUM UNIT OPTIONS:
 - w/ 10 HP, 3-PHASE MOTOR: PART # 96-0062.
 - w/ 7.5 HP, 1-PHASE MOTOR: PART # 96-0079 (REDUCED WEIGHT).

Drum Drive Unit

Standard Version — Part # 96-0062

Reduced Weight Version — Part # 96-0079

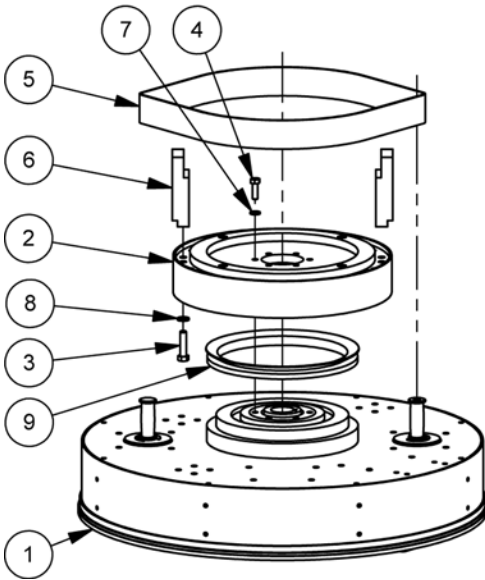

ITEM	DESCRIPTION	PART #	QTY
1	Drum assy	see note 2	1
2	Motor base assy	53-0026	1
3	Screw (hex head), 3/8 - 16 x 1-1/2	11-0089	4
4	Screw (hex head), 5/16 - 18 x 1, grade 8	11-0192	6
5	Belt, 1-3/4 W x 43-3/4 L	13-0164	1
6	Post	51-0219	2
7	Washer (split lock), 5/16	11-0127	6
8	Washer (split lock), 3/8	11-0129	4
9	Seal (V-ring), 198 ID x 25mm width	13-0165	1

REV --

NOTE:

1. THIS ILLUSTRATION SERVES TO PRIMARILY SHOW HOW PARTS/ COMPONENTS FIT TOGETHER FOR THE ASSEMBLY OF THIS UNIT. IT MAY NOT NECESSARILY REFLECT THE AS-BUILT STAGES AND/ OR HARDWARES ASSIGNED TO THE COMPONENTS.
2. DRUM ASSY OPTIONS: USE P/N 96-0059 FOR DRUM DRIVE UNIT STANDARD VERSION, P/N 96-0080 FOR DRUM DRIVE UNIT REDUCED WEIGHT VERSION.

Belt Routing

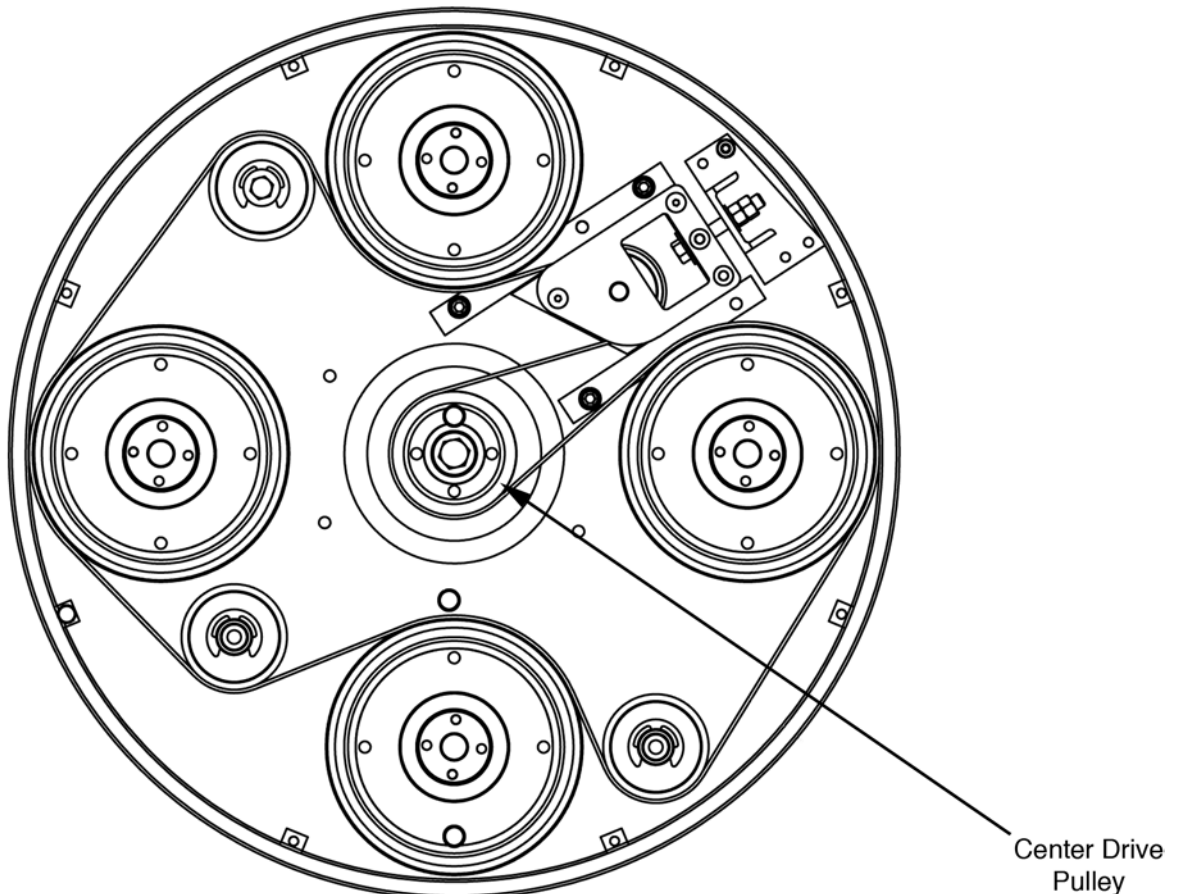

ATTENTION: BELT'S GREY COLORED SIDE TO FACE TOWARD CENTER DRIVE PULLEY.

Drum Assembly

Standard Version — Part # 96-0059

Reduced Weight Version — Part # 96-0080

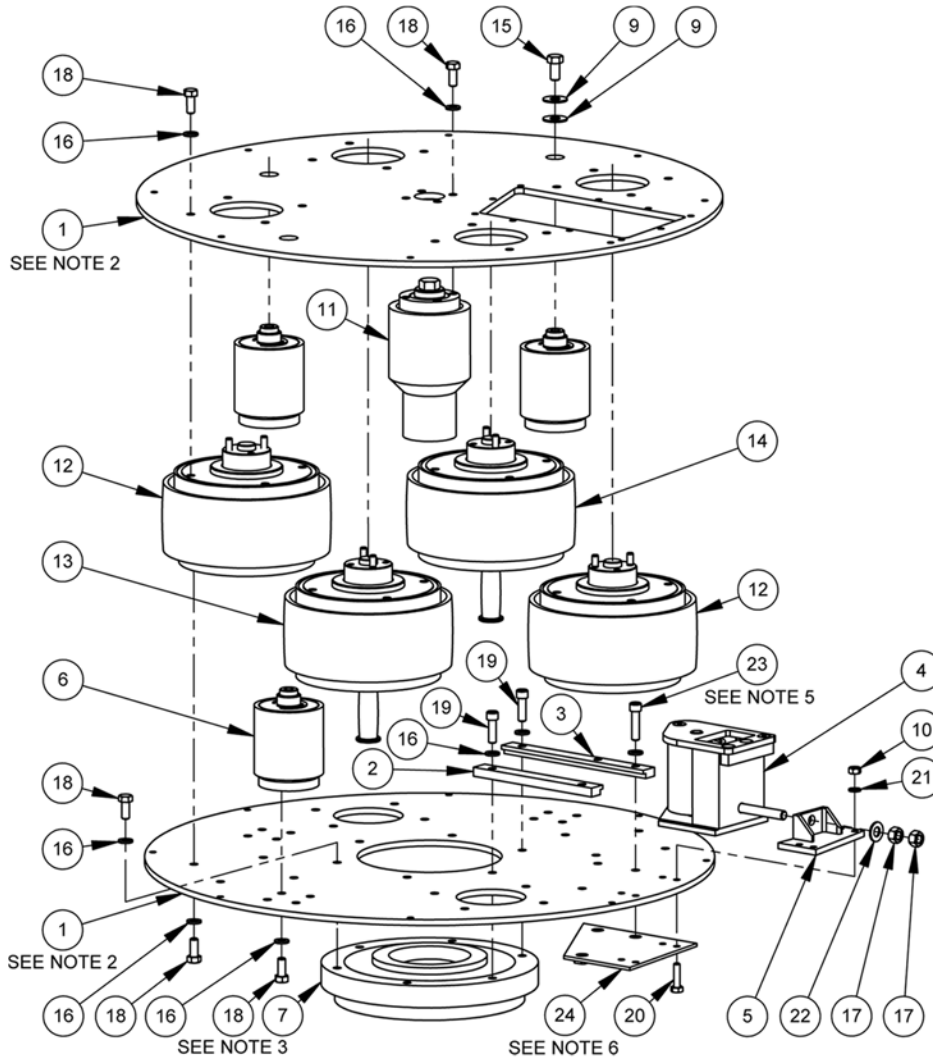

ITEM	DESCRIPTION	PART #	QTY
1	Drum top/bottom plate	see note 2	1
2	Tensioner sliding track (2 holes)	51-0198	1
3	Tensioner sliding track (3 holes)	51-0197	1
4	Tensioner sliding unit	96-0052	1
5	Tensioner stationary anchor	53-0027	1
6	Idler assy	96-0019	3
7	Bearing assy (drum / motor base connection)	96-0057	1
hidden	Belt	13-0163 see note 4	1
9	Washer, 3/8	11-0035	6
10	Nut, 1/4 - 20	11-0123	4
11	Pulley (center drive)	96-0054	1
12	Cutter head pulley assy	96-0049	2
13	Cutter head pulley assy (with flanged top pulley)	96-0050	1
14	Cutter head pulley assy (with insert-flanged top pulley)	96-0051	1
15	Screw (hex head), 3/8 - 16 x 3/4	11-0130	3
16	Washer (split lock), 5/16	11-0127	55
17	Nut, 3/8 - 16	11-0124	2
18	Screw (hex head), 5/16 - 18 x 3/4, grade 8	11-0193	50
19	Screw (socket head cap), 5/16 - 18 x 1	11-0171	2
20	Screw (hex head), 1/4 - 20 x 1	11-0121	4
21	Washer (split lock), 1/4	11-0069	4
22	Washer (SAE), 3/8	11-0126	1
23	Screw (socket head cap), 5/16 - 18 x 3/4 or 1-1/4 length. See note 5	see note 5	3
24	Tensioner tracks adapter plate	see note 6	1

REV --

NOTES:
 1. FOR ILLUSTRATION SIMPLICITY, NOT ALL PARTS ARE SHOWN OR LABELED.
 2. DRUM TOP AND BOTTOM PLATES ARE COMPONENTS OF DRUM ENVELOPE. TO SHOW HOW PARTS FIT TOGETHER, NOT ALL OF DRUM ENVELOPE'S PARTS ARE SHOWN. DRUM ENVELOPE OPTIONS: USE P/N 96-0056 FOR STANDARD DRUM ASSY VERSION, P/N 96-0088 FOR REDUCED WEIGHT DRUM ASSY VERSION.
 3. USAGE OF INDICATED WASHERS FOR IDLERS INSTALLATION ARE MANDATORY TO ENSURE SCREWS ENDS WILL NOT TOUCH ROTATING BEARINGS UNDERNEATH.
 4. ASSY'S DRIVE BELT IS NOT SHOWN HERE DUE TO SPACE CONSTRAINTS. REFER TO BELT ROUTING ILLUSTRATION FOR BELT LAYOUT ON ASSY.
 5. INDICATED SCREW OPTIONS: USE 3/4" LENGTH (P/N 11-0172) FOR STANDARD DRUM ASSY VERSION, 1-1/4" LENGTH (P/N 11-0227) FOR REDUCED WEIGHT VERSION.
 6. USE INDICATED ADAPTER PLATE (P/N 53-0037) ON REDUCED WEIGHT DRUM ASSY

Drum Envelope

Standard Version — Part # 96-0056

Reduced Weight Version — Part # 96-0088

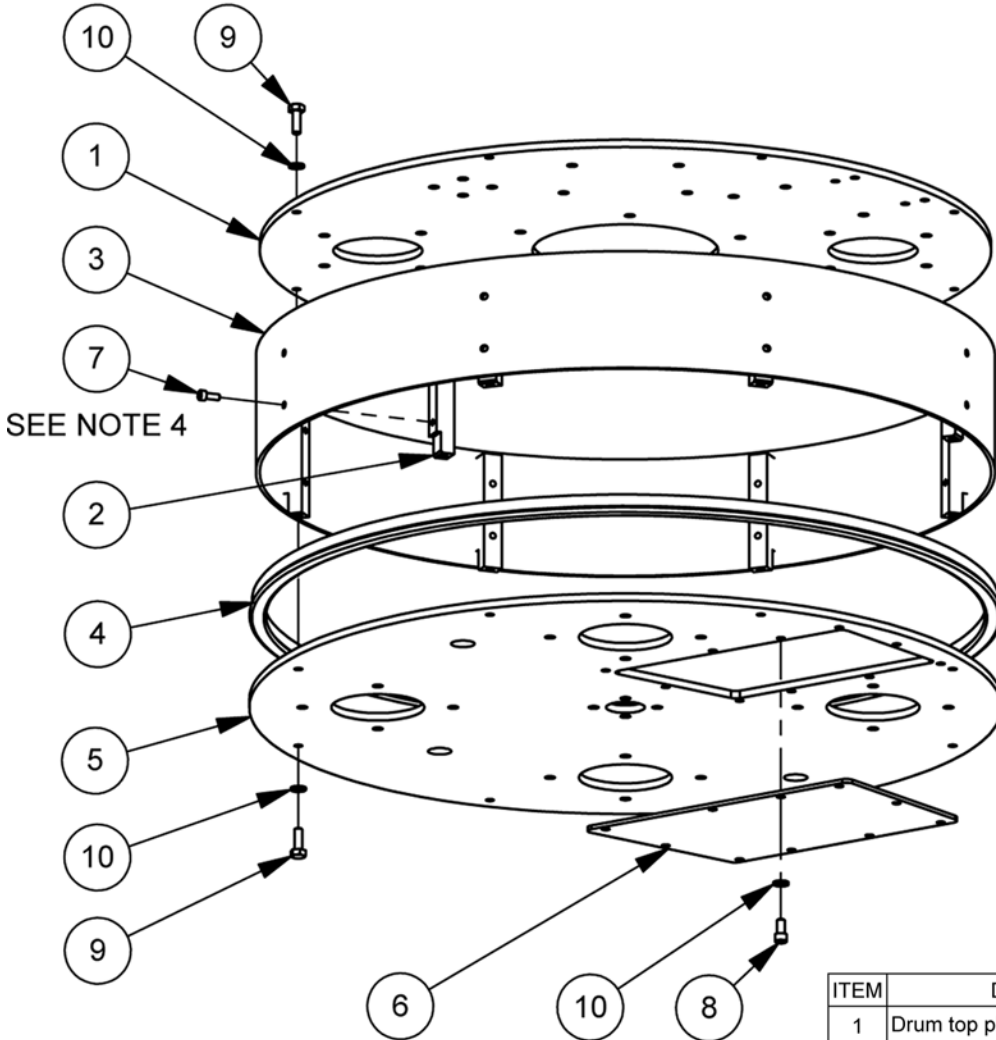

ITEM	DESCRIPTION	PART #	QTY
1	Drum top plate	see note 2	1
2	Spacer bar	51-0022	8
3	Drum side wall	53-0031	1
4	Seal (edge trim)	03-0001	1
5	Drum bottom plate	see note 3	1
6	Cover plate (tensioner access hole)	51-0206	1
7	Screw (socket head), #10 - 24 x 1/2	11-0149	16
8	Screw (socket head), 1/4 - 20 x 1/2	11-0164	10
9	Screw (hex head), 1/4 - 20 x 3/4	11-0133	16
10	Washer (split lock), 1/4	11-0069	26

REV --

NOTES:

1. FOR ILLUSTRATION SIMPLICITY, NOT ALL PARTS ARE SHOWN OR LABELED.
2. DRUM TOP PLATES OPTIONS: USE P/N 51-0203 FOR DRUM ENVELOPE STANDARD VERSION, P/N 51-0289 FOR DRUM ENVELOPE REDUCED WEIGHT VERSION.
3. DRUM BOTTOM PLATES OPTIONS: USE P/N 51-0204 FOR DRUM ENVELOPE STANDARD VERSION, P/N 51-0290 FOR REDUCED WEIGHT VERSION.
4. SECURE INDICATED SCREW(S) WITH A MEDIUM STRENGTH THREAD LOCKING COMPOUND (IE. LOCTITE 242).
5. SEAL JOINT BETWEEN DRUM SIDE WALL AND TOP PLATE, AS WELL AS SPACER BARS, WITH SILICONE.
6. SEAL PERIMETER OF COVER PLATE WITH SILICONE AFTER ATTACHMENT TO DRUM BOTTOM PLATE.

Tension Sliding Unit — # 96-0052

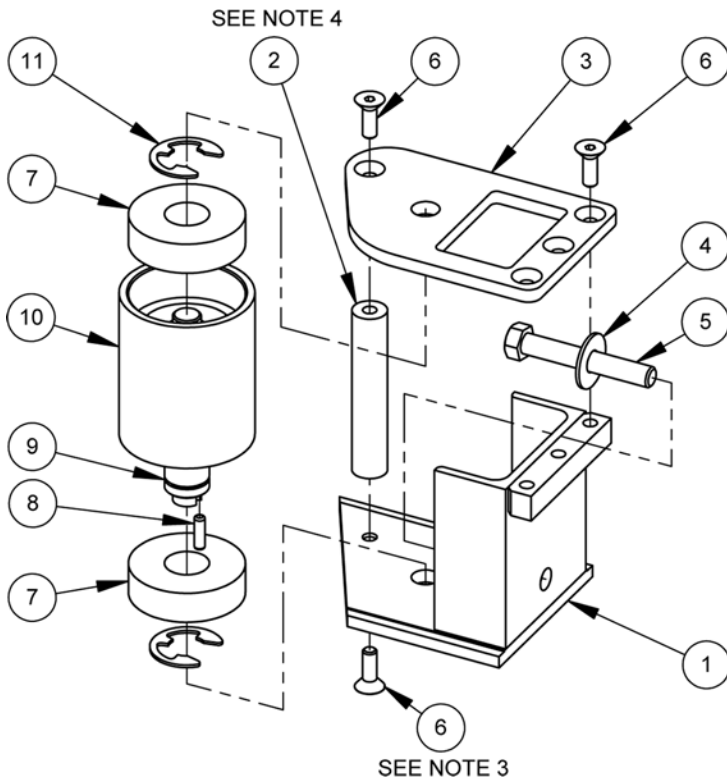

ITEM	DESCRIPTION	PART #	QTY
1	Tensioner sliding base (welded assy)	53-0024	1
2	Tensioner top plate support post	51-0200	1
3	Tensioner top plate	51-0195	1
4	Washer (SAE), 3/8	11-0126	1
5	Screw (hex head, fully threaded), 3/8 - 16 x 2-1/2	11-0122	1
6	Screw (flat head, socket head), 1/4 - 20 x 3/4	11-0140	5
7	Bearing, 20 ID x 52 OD x 15 H (mm)	13-0122	2
8	Pin (dowel), 3/16 dia. x 5/8 long	13-0133	1
9	Shaft, .787 dia.	51-0017	1
10	Idler (sleeve roller), 2-3/8 dia. x 2-7/8 high	51-0018	1
11	Retaining ring (E-style)- for 7/8 dia. shaft	13-0137	2

REV --

NOTES:

1. FOR ILLUSTRATION SIMPLICITY, NOT ALL DUPLICATE ITEMS ARE SHOWN OR LABELED.
2. IDLER'S END WITH SHALLOW INTERNAL COUNTER-BORE FACES TOWARD SLIDING BASE.
3. SECURE INDICATED SCREW WITH A MEDIUM STRENGTH THREAD LOCKING COMPOUND (IE. LOCTITE 242).
4. MANUFACTURING NOTE: TAG-WELD SUPPORT POST TO SLIDING BASE TO PREVENT ROTATIONAL MOVEMENT.

Bearing Assembly (Drum/Motor Base Connection) — Part # 96-0057

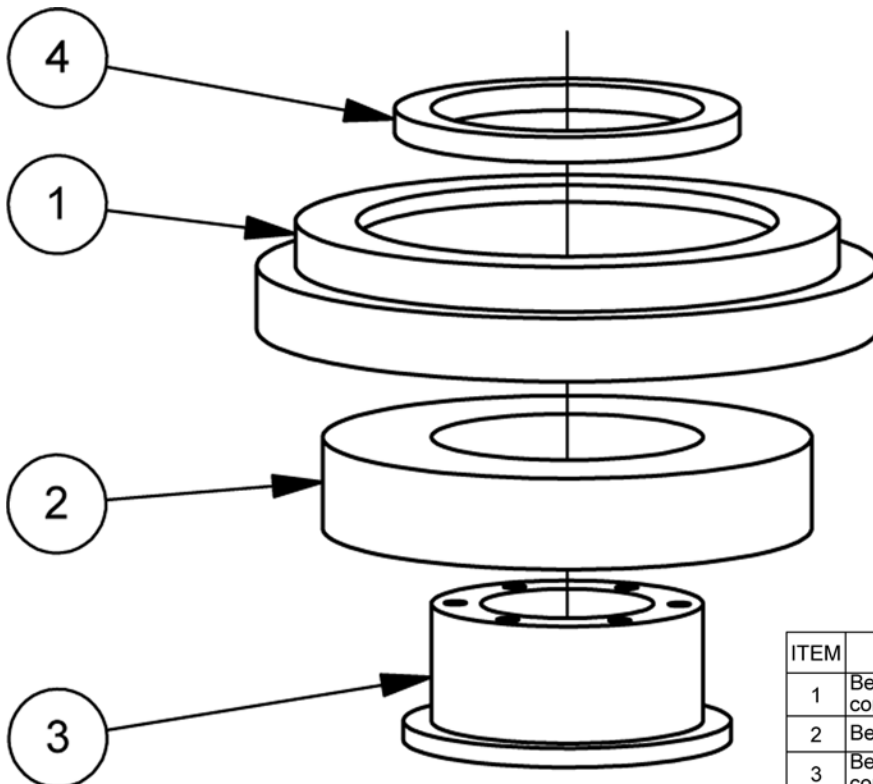

ITEM	DESCRIPTION	PART #	QTY
1	Bearing housing (rotating drum connection, outer housing)	51-0212	1
2	Bearing, 100 ID x 180 OD x 34mm high	13-0160	1
3	Bearing housing (rotating drum connection, inner housing)	51-0211	1
4	Spacer ring, 3.94 ID x 5 OD x 3/8" thick	51-0213	1

REV --

Cutter Head Pulley Assembly (Cast Unit) — # 96-0049

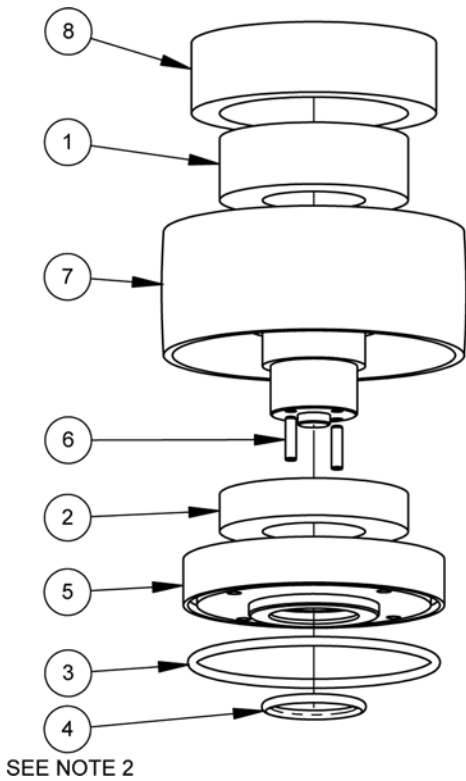

ITEM	DESCRIPTION	PART #	QTY
1	Bearing, 60 ID x 110 OD x 22 mm high	13-0119	1
2	Bearing, 60 ID x 110 OD x 36.5 mm high	13-0120	1
3	O-ring, 5-3/8 ID x 5-3/4 OD x 3/16" width	13-0130	1
4	O-ring, 2 ID x 2-3/8 OD x 3/16" width	13-0131	1
5	Bearing housing (cutter head, bottom)	51-0001	1
6	Pin (dowel), 1/4 dia. x 1" long	13-0134	2
7	Cutter head pulley- cast unit	51-0191-3	1
8	Bearing housing (cutter head, top)	51-0216	1

REV --

NOTES:

1. FOR ILLUSTRATION SIMPLICITY, NOT ALL PARTS ARE SHOWN OR LABELED.
2. INDICATED O-RING TO BE INSERTED INTO PROVIDED INTERNAL GROOVE ON BODY OF BOTTOM BEARING HOUSING.

Cutter Head Pulley Assembly (With Flanged Top Pulley, Cast Unit) — # 96-0050

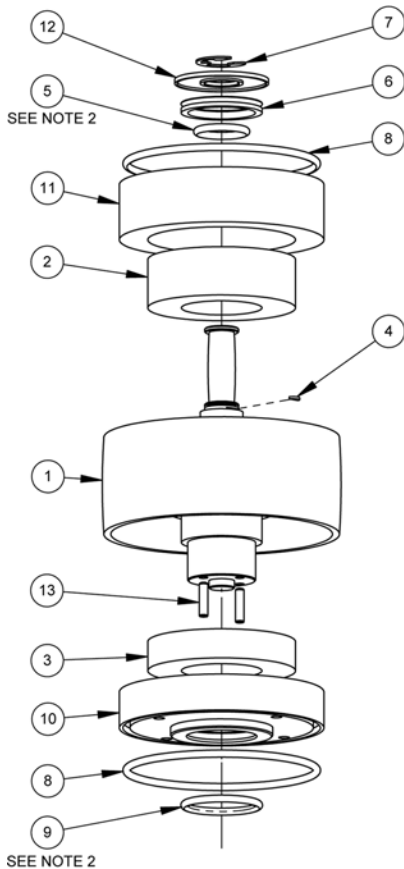

ITEM	DESCRIPTION	PART #	QTY
1	Cutter head pulley (w/ flanged top pulley)- cast unit	51-0191-1	1
2	Bearing, 60 ID x 110 OD x 36.5 mm high	13-0120	1
3	Bearing, 60 ID x 110 OD x 22 mm high	13-0119	1
4	Key (woodruff, full radius), .063 thick x .375" dia.	13-0140	1
5	O-ring, 1-1/4 ID x 1-5/8 OD x 3/16" width	13-0132	1
6	Seal (V-ring), 45 ID x 9 mm high	13-0124	1
7	Retaining ring (E-style)- for 1" shaft	13-0135	1
8	O-ring, 5-3/8 ID x 5-3/4 OD x 3/16" width	13-0130	2
9	O-ring, 2 ID x 2-3/8 OD x 3/16" width	13-0131	1
10	Bearing housing (cutter head, bottom)	51-0001	1
11	Bearing housing (cutter head, w/ top pulley provision)	51-0215	1
12	Cover disc (dust seal), 2.75" dia.	51-0027	1
13	Pin (dowel), 1/4 dia. x 1" long	13-0134	2

REV --

NOTES:

1. FOR ILLUSTRATION SIMPLICITY, NOT ALL PARTS ARE SHOWN OR LABELED.
2. INDICATED O-RING TO BE INSERTED INTO PROVIDED INTERNAL GROOVE ON BODY OF BEARING HOUSING.

Cutter Head Pulley Assembly (With Insert-Flanged Top Pulley, Cast Unit) — # 96-0051

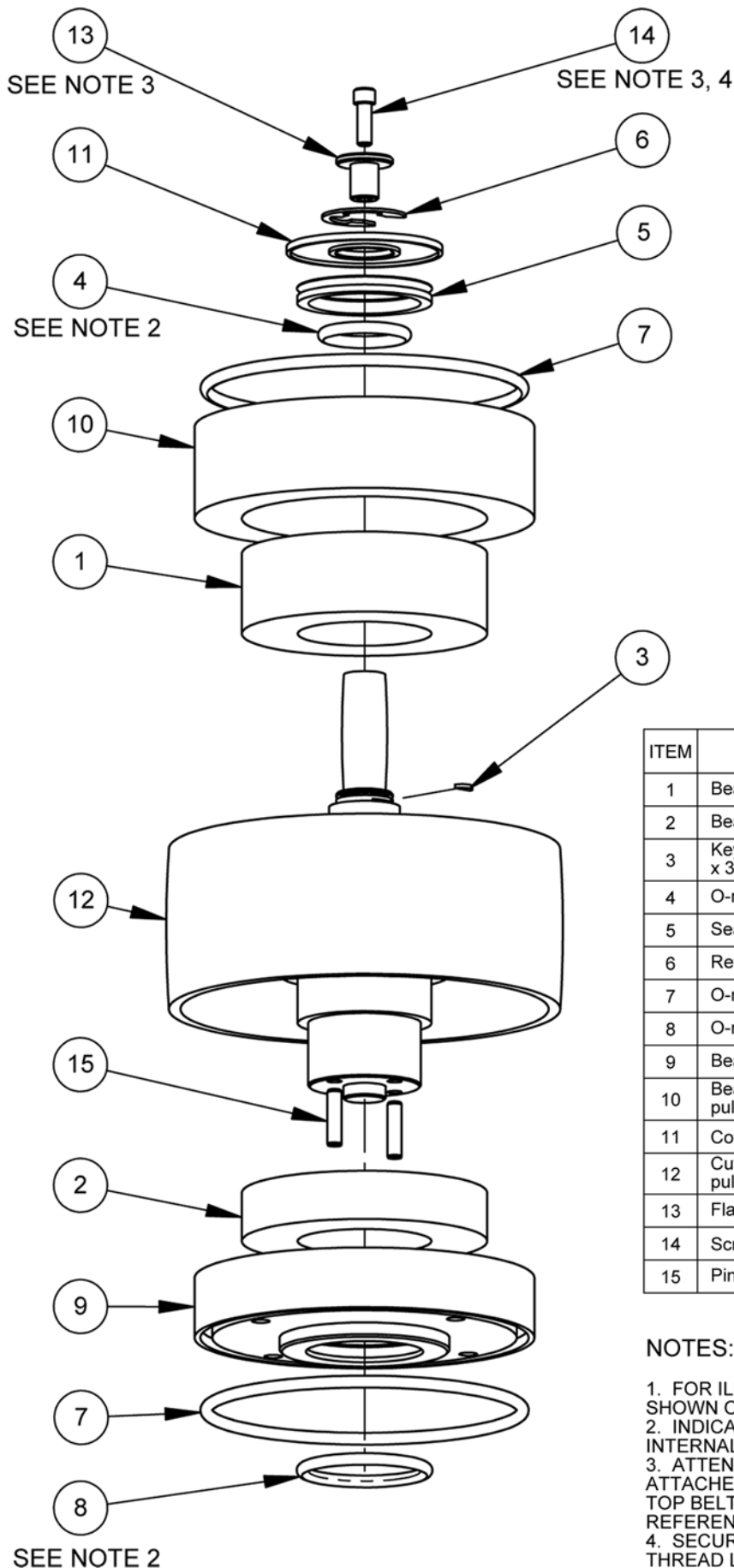

ITEM	DESCRIPTION	PART #	QTY
1	Bearing, 60 ID x 110 OD x 36.5 mm high	13-0120	1
2	Bearing, 60 ID x 110 OD x 22mm high	13-0119	1
3	Key (woodruff, full radius), 1/16 thick x 3/8 dia.	13-0140	1
4	O-ring, 1-1/4 ID x 1-5/8 OD x 3/16" width	13-0132	1
5	Seal (V-ring), 45 ID x 9 mm high	13-0124	1
6	Retaining ring (E-style)- for 1" shaft	13-0135	1
7	O-ring, 5-3/8 ID x 5-3/4 OD x 3/16" width	13-0130	2
8	O-ring, 2 ID x 2-3/8 OD x 3/16" width	13-0131	1
9	Bearing housing (cutter head, bottom)	51-0001	1
10	Bearing housing (cutter head, w/ top pulley provision)	51-0215	1
11	Cover disc (dust seal), 2.75" dia.	51-0027	1
12	Cutter head pulley (w/ non-flanged top pulley)- cast unit	51-0191-2	1
13	Flange insert (for top drive pulley)	51-0157	1
14	Screw (socket head), 1/4 - 20 x 3/4"	11-0169	1
15	Pin (dowel), 1/4 dia. x 1" long	13-0134	2

REV --

NOTES:

1. FOR ILLUSTRATION SIMPLICITY, NOT ALL PARTS ARE SHOWN OR LABELED.
2. INDICATED O-RING TO BE INSERTED INTO PROVIDED INTERNAL GROOVE ON BODY OF BEARING HOUSING.
3. ATTENTION: FLANGE INSERT AND SCREW TO BE ATTACHED AFTER INSTALLATION OF GRINDER HEAD'S TOP BELT. SEE DRUM DRIVE UNIT ILLUSTRATION FOR REFERENCE.
4. SECURE INDICATED SCREW WITH A MEDIUM STRENGTH THREAD LOCKING COMPOUND (IE. LOCTITE 242).

Pulley Assembly (Center Drive) — # 96-0054

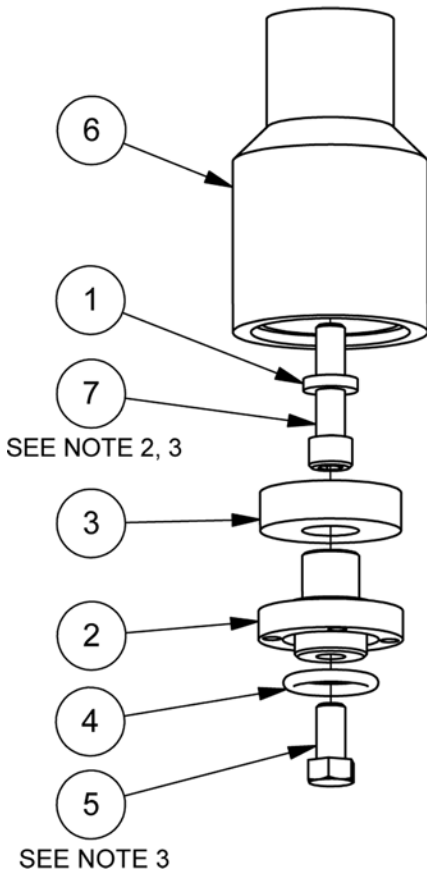

NOTES:

1. FOR ILLUSTRATION SIMPLICITY, NOT ALL PARTS ARE SHOWN.
2. INDICATED SCREW TO BE USED FOR ATTACHING PULLEY ASSEMBLY TO MOTOR SHAFT.
3. SECURE INDICATED SCREW(S) USING A MEDIUM STRENGTH THREAD LOCKING COMPOUND.

ITEM	DESCRIPTION	PART #	QTY
1	Washer (custom made), .5 ID x .94 OD x .2" thk	51-0102	1
2	Shaft (center drive pulley support)	51-0039	1
3	Bearing, 25 ID x 62 OD x 17mm high	13-0121	1
4	O-ring, 1-1/4 ID x 1-5/8 OD x 3/16 width	13-0132	1
5	Bolt (hex head), 1/2 - 13 x 1	11-0147	1
6	Pulley, 3-3/8 dia.	51-0214	1
7	Screw (socket head), 1/2 - 13 x 2	11-0170	1

REV --

Idler Assembly — # 96-0019

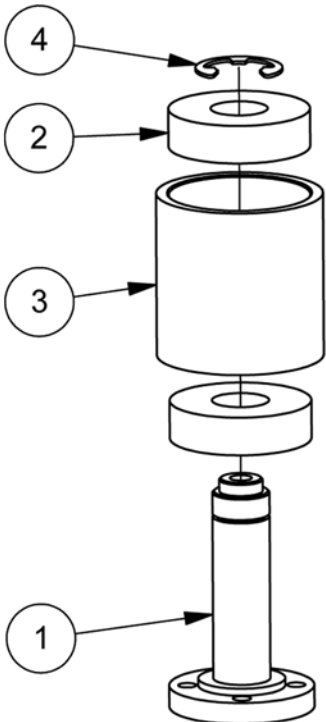

ITEM	DESCRIPTION	PART #	QTY
1	Shaft (for main drive idler), .984" dia.	51-0021	1
2	Bearing, 25 ID x 62 OD x 17 mm high	13-0121	2
3	Idler (sleeve roller), 2-7/8 dia. x 2-7/8 high	51-0020	1
4	Retaining ring (E-style)- for 1" shaft	13-0135	1

REV --

Cutter Head Floating Head Unit — # 96-0065

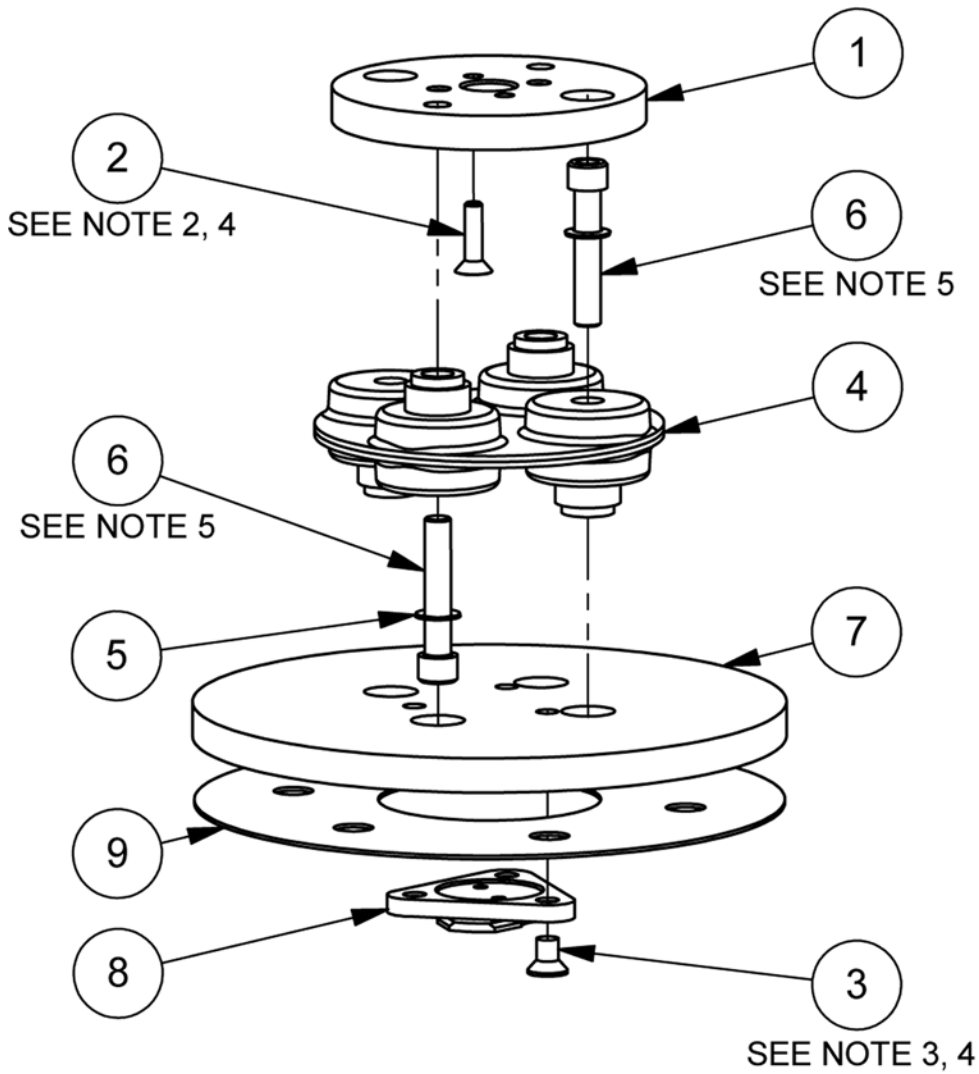

NOTES:

1. FOR ILLUSTRATION SIMPLICITY, NOT ALL PARTS ARE SHOWN OR LABELED.
2. INDICATED SCREW(S) IS USED FOR ATTACHING ASSEMBLY TO CUTTER HEAD SHAFT.
3. INDICATED SCREW(S) HAS AN "UNDERCUT" HEAD FEATURE TO AVOID POSSIBLE FITTING INTERFERENCE PROBLEMS.
4. SECURE INDICATED SCREW(S) USING A MEDIUM STRENGTH THREAD LOCKING COMPOUND (IE. LOCTITE 242).
5. SECURE INDICATED SCREW(S) USING A HIGH STRENGTH THREAD LOCKING COMPOUND (IE. LOCTITE 271).

ITEM	DESCRIPTION	PART #	QTY
1	Cutter head floating head top plate	51-0140	1
2	Screw (flat head, hex socket), 1/4 - 20 x 1	11-0120	2
3	Screw (flat head, Phillips), 5/16 - 18 x 1/2	11-0206	3
4	Flexible coupling	13-0056	1
5	Washer (Belleville, serrated), .413 ID x .630 OD	11-0162	4
6	Screw (socket head), 3/8 - 24 x 2	11-0147	4
7	Cutter head floating head bottom plate	51-0240	1
8	Cutter head triangle holder assy	96-0063	1
9	Cutter head velcro mat	13-0168	1

REV --

Cutter Head Triangle Holder Assembly — # 96-0063

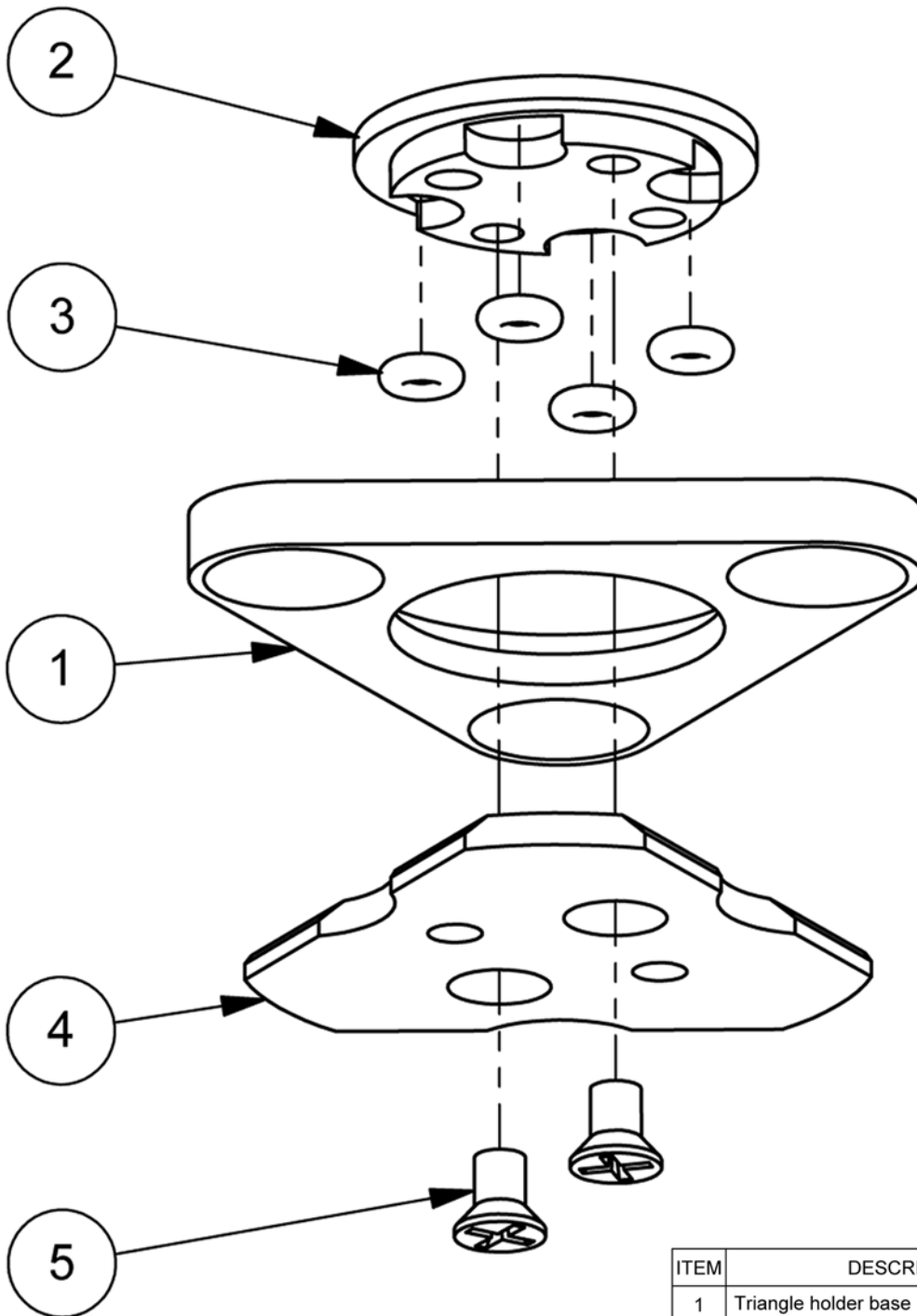

SEE NOTE 2

ITEM	DESCRIPTION	PART #	QTY
1	Triangle holder base	51-0244	1
2	Triangle holder center rotator	51-0110	1
3	O-ring, 1/8 ID x 5/16 OD x 3/32 width	13-0142	4
4	Triangle holder hold-down	51-0246	1
5	Screw (flat head, Phillips), #10 - 24 x 5/16	11-0142	2

REV --

NOTES:

1. FOR ILLUSTRATION SIMPLICITY, NOT ALL PARTS ARE SHOWN OR LABELED.
2. ATTACH INDICATED SCREWS TO CENTER ROTATOR USING A HIGH STRENGTH THREAD LOCKING COMPOUND (IE. LOCTITE 271). SCREW HEADS HAVE AN "UNDERCUT" FEATURE TO AVOID POSSIBLE PARTS FITTING INTERFERENCE PROBLEMS.

Inverter Unit

10 Horse Power, 3 Phase Motor — Part # 96-0072

7.5 Horse Power, 1 Phase Motor — Part # 96-0073

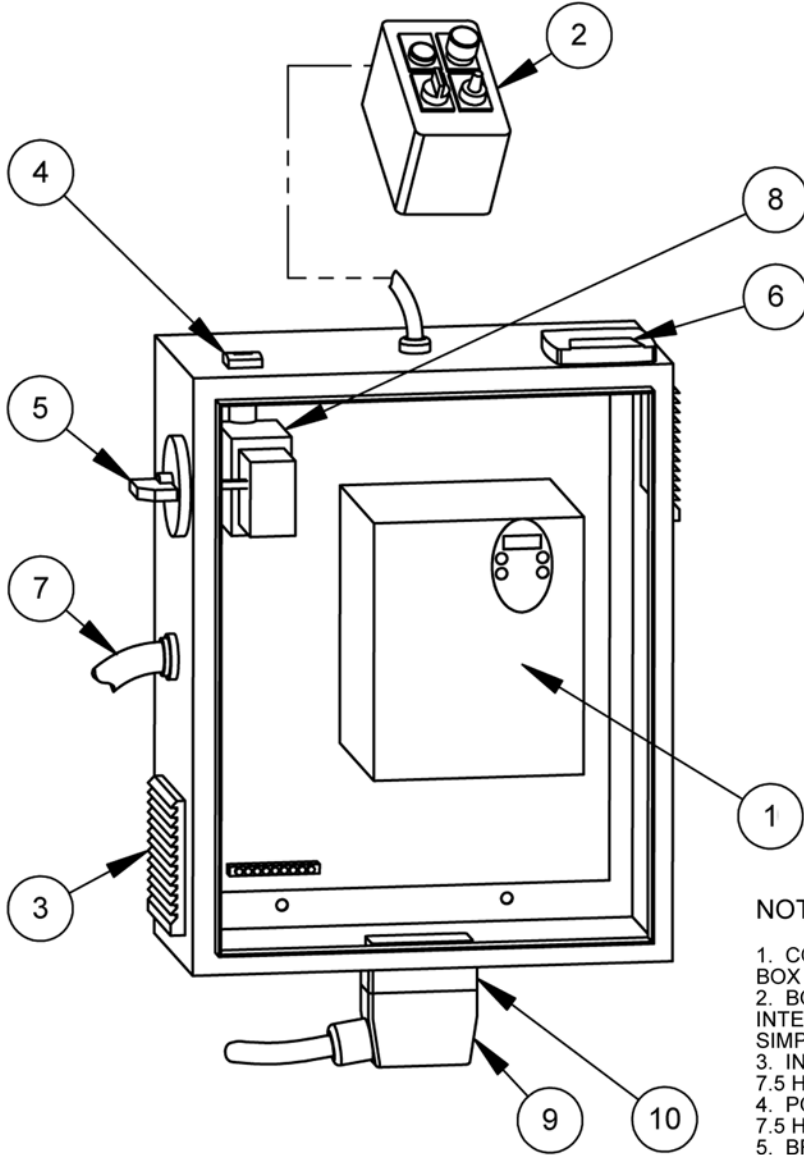

NOTES:

1. CONTROL BOX, CONNECTING CABLE, AND INVERTER BOX ARE PRE-WIRED TOGETHER AS ONE UNIT.
2. BOX LID HIDDEN TO SHOW INTERNAL COMPONENTS. INTERNAL WIRING NOT SHOWN FOR ILLUSTRATION SIMPLICITY.
3. INVERTER: 10 HP 3-PHASE MOTOR: PART # 23-0066, 7.5 HP 1-PHASE MOTOR: PART # 23-0067.
4. POWER CABLE: 10 HP 3-PHASE MOTOR: PART # 24-0025, 7.5 HP 1-PHASE MOTOR: PART # 24-0026.
5. BREAKER: 10 HP 3-PHASE MOTOR: PART # 23-0069, 7.5 HP 1-PHASE MOTOR: PART # 23-0070.

ITEM	DESCRIPTION	PART #	QTY
1	Inverter	see note 3	1
2	[Power] control box	23-0052	1
3	Vent cover	25-0076	2
4	Hour meter	23-0061	1
5	Switch (On/Off)	22-0019	1
6	Amp meter	23-0068	1
7	Cable (power in)	see note 4	1
8	Circuit breaker	see note 5	1
9	Cable (inverter / motor connection)	24-0027	1
10	Connector plug (inverter / motor connection)	23-0056	1

REV --

One Phase Wiring Schematic

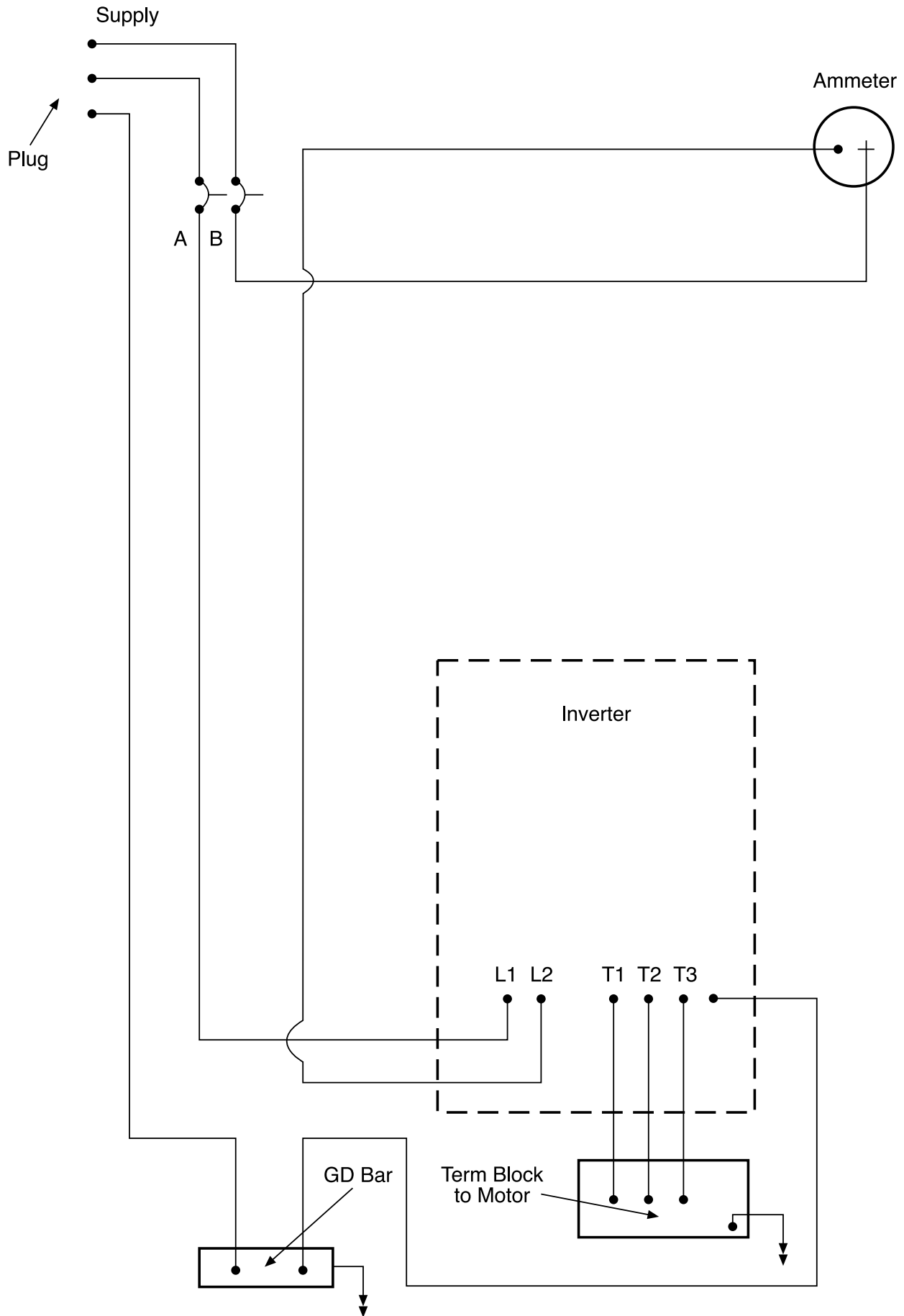

Controls Wiring Schematic

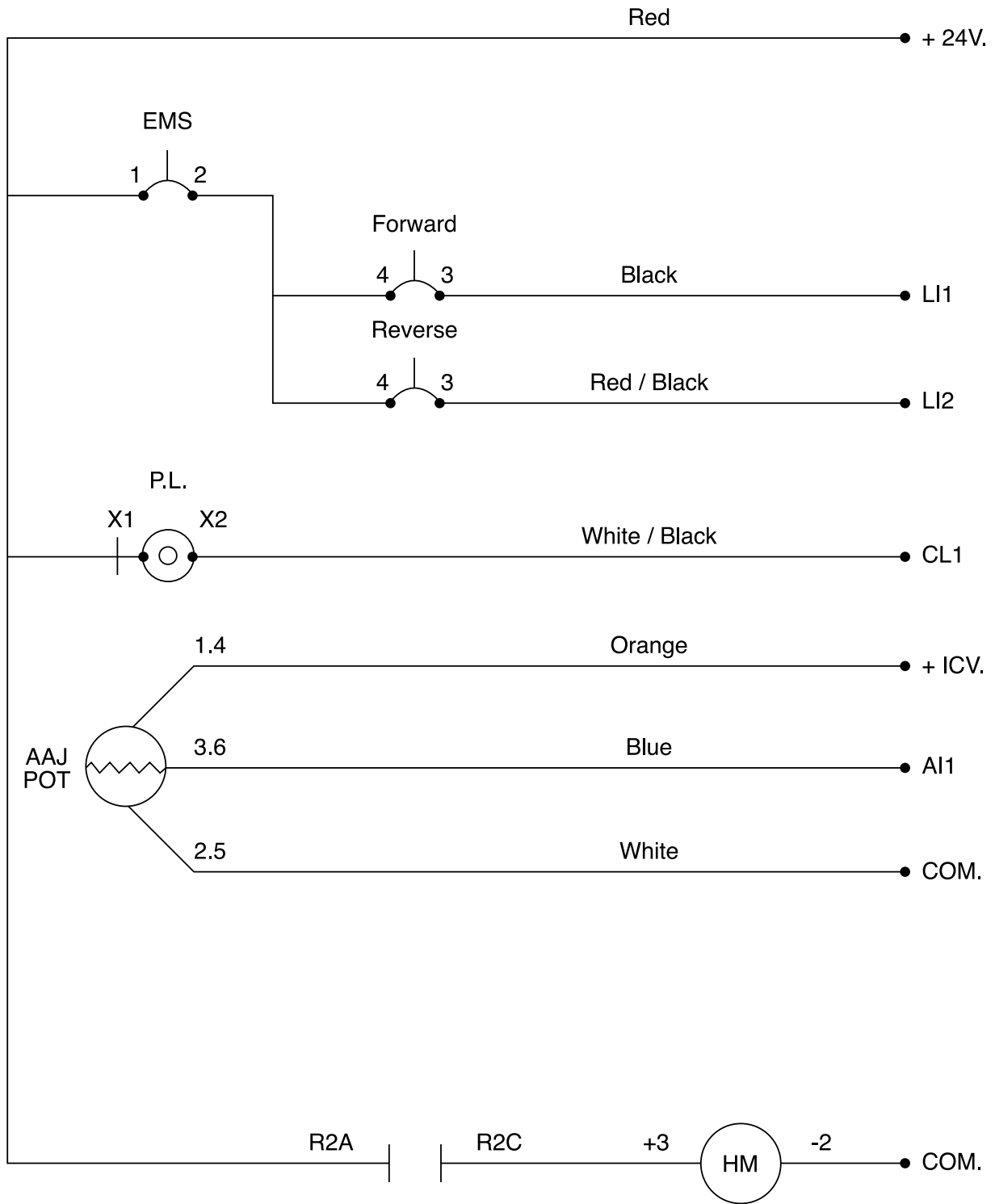

PREDATOR GRINDER UPPER BELT CHANGE

STEP 1 – Remove plastic dust shroud.



STEP 2 – Remove screw and washers on one side.

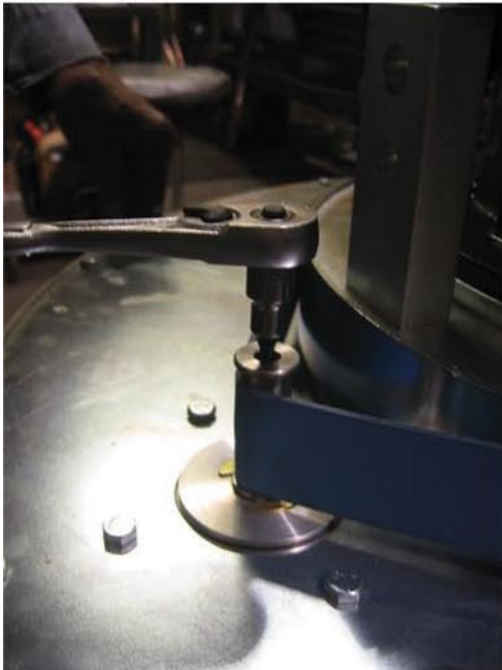

STEP 3 – Place the new belt over the motor and one pulley loosely.

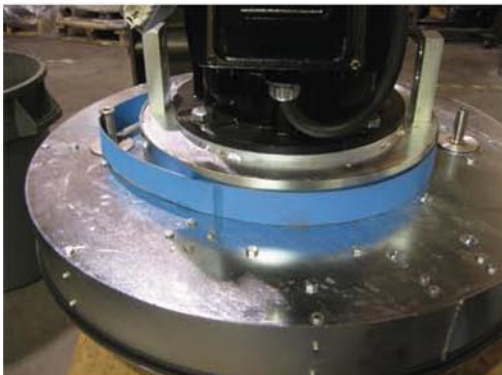

STEP 4 – Screw in the belt hold down on both sides of the motor.



Finished hold downs on both sides.

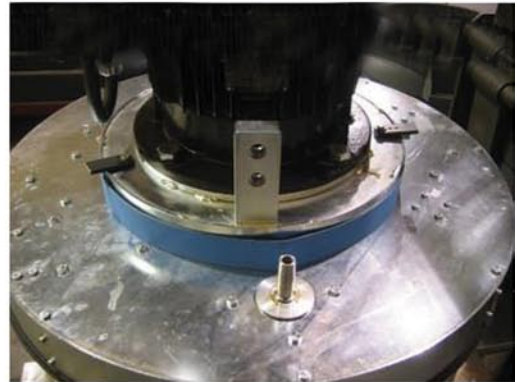

STEP 5 – Insert bar through belt and insert round end into the screw hole.

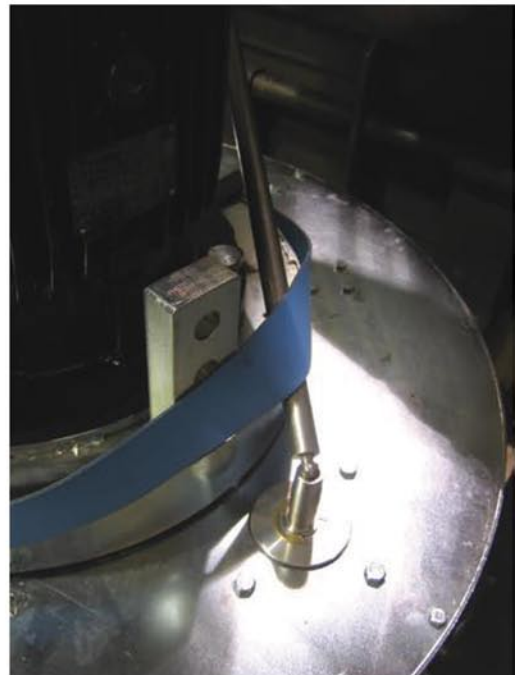

PREDATOR GRINDER UPPER BELT CHANGE

STEP 6 – Pull back on the bar and slip belt over the shaft.

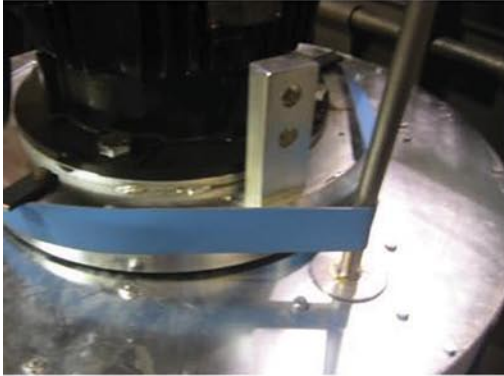

STEP 7 – Use flat head screw driver to pull remaining belt over the lip.



Belt installation complete.

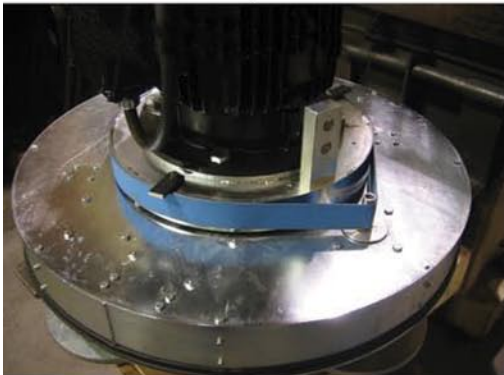

STEP 8 – Add Loc-tite 242 supplied with kit to the screw threads.



STEP 9 – Replace the screw and washer.



STEP 10 – Remove belt guides and replace dust shroud.



PREDATOR GRINDER INNER BELT CHANGE

STEP 1 – Remove grinding heads.

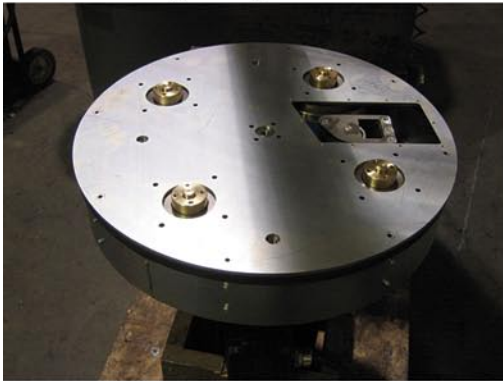

STEP 2 – Remove all bolts and inspection plate.

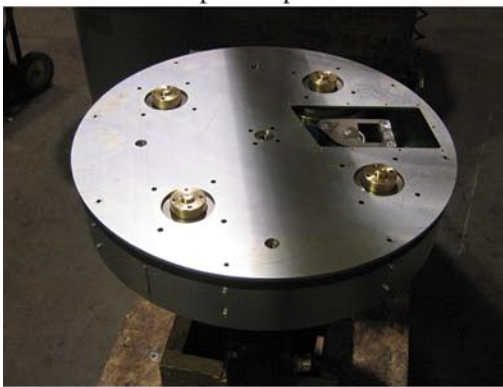

STEP 3 – Remove bottom plate.



STEP 4 – Unscrew bolts to loosen Belt Tensioner.

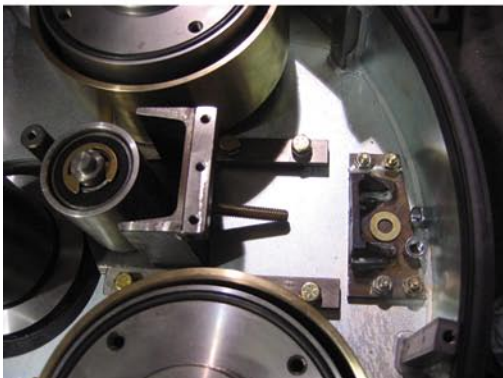

STEP 5 – Loop belt over pulleys. (Grey side goes toward the center pulley.)



STEP 6 – Lightly tighten base bolts and slide the screw through the hole.

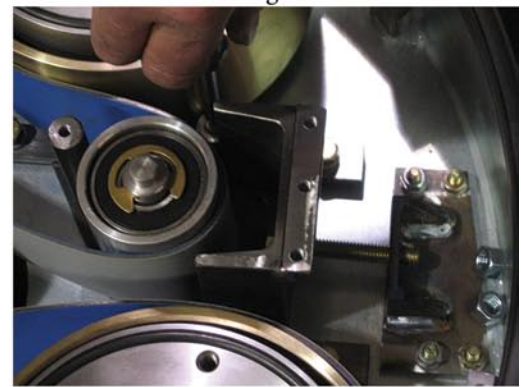

STEP 7 – Put the nut and washer on the screw and add a drop of oil to the screw.

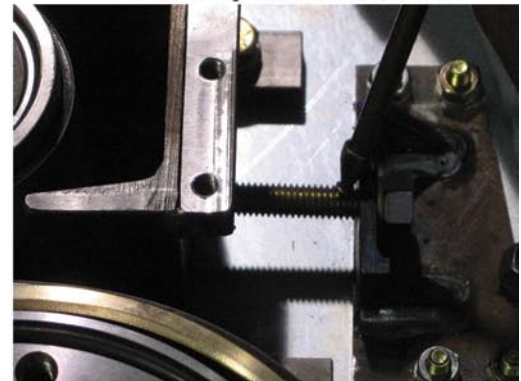

STEP 8 – Put on the top plate of the Belt Tension and screw in.

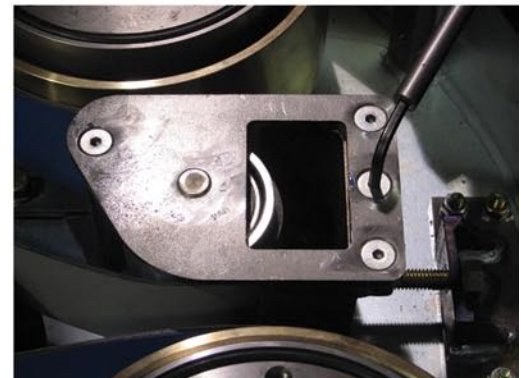

PREDATOR GRINDER INNER BELT CHANGE

STEP 9 – Replace the bottom plate.

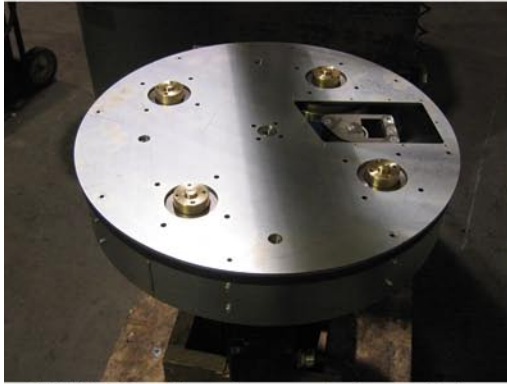

STEP 10 – Align the screw holes on all the pulleys and put one bolt in each pulley.

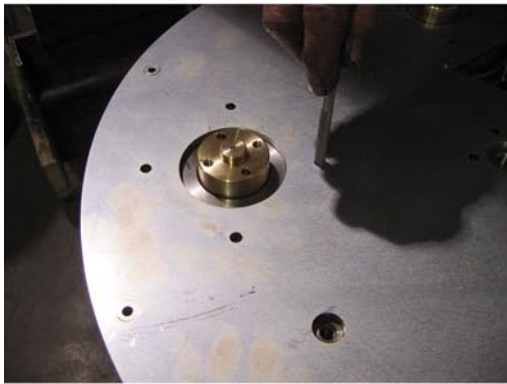

Remember to use blue locktite on screws with flat washers.

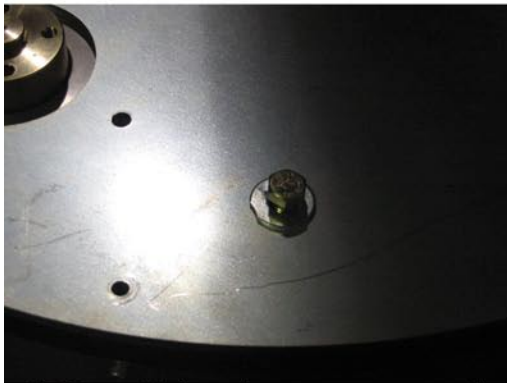

STEP 11 – Tighten down one screw on each pulley and four main bolts tight.

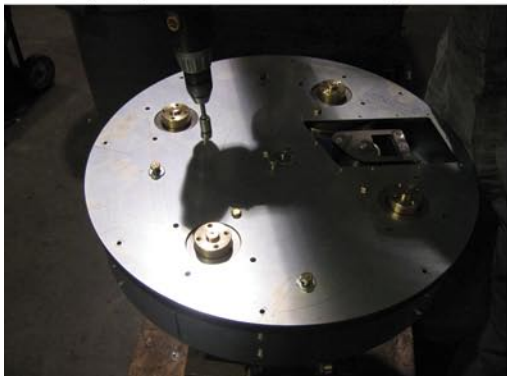

Remember to put lock washers back on screws.



STEP 12 – Tighten in all remaining screws with lock washers.

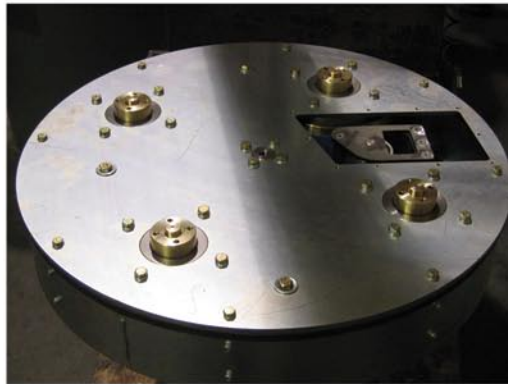

STEP 13 – Tighten the bolt on the Belt Tensioner to tighten the inner belt.

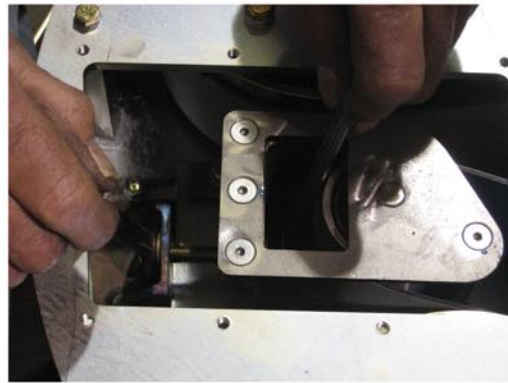

STEP 14 – Halfway through tightening of inner belt, add second nut to screw. Tighten until screw is 1/16" away from inside plate.



PREDATOR GRINDER INNER BELT CHANGE

STEP 15 – Tighten down base bolts on the Belt Tensioner.

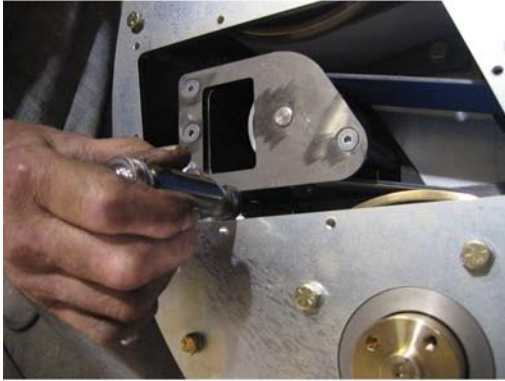

STEP 16 – Replace inspection cover, tighten screws with lock washers, and then silicone around the edge.

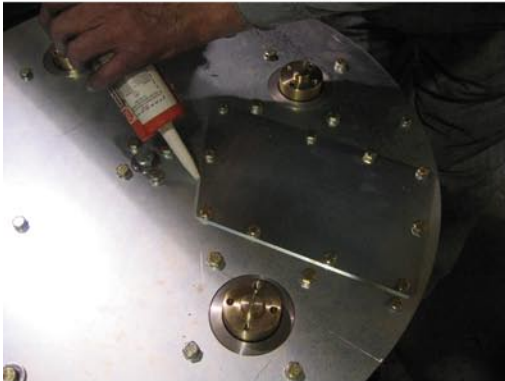

STEP 17 – The inner belt replacement is complete. Replace grinding heads.

